



ARCHITECTURAL & PRELIMINARY SITE PLAN REVIEW BOARD

MICHAEL F. LONGOBARDI – VILLAGE TRUSTEE LIAISON
TIMOTHY T. TWEEDY, P.E. – CHAIRMAN
JOHN LOCKWOOD
ANTHONY KRUYNSKI
ROGER KUEHNLENZ
EDWARD CHATTERTON

RENEE MARCUS, AIA – SUPERINTENDENT OF BUILDINGS
LUCILLE LANGONE – SECRETARY

JUNE 27, 2024

8:00 pm

Note Location: Recreation Center/Pool Building

Case No.	Approximate Time	Address #	Street	Description	Owner	Design Professional
1	8:00 p.m.	7	Verbena Avenue	Re-submission - Sign	Shalini Tiwari	Dezant Signs Inc.
2	8:05 p.m.	271	Jericho Turnpike	Sign	Ravin Patel	Dezant Signs Inc.
3	8:10 p.m.	97	Emerson Avenue	Front Canopy and Stoop Reconstruction	Ryan Cummings	Demetris Demetriou
4	8:20 p.m.	286	Tulip Avenue	Sunroom Conversion	David Giesbrecht & Rachel Neville	Jeffrey Butler, PE
5	8:30 p.m.	183	Aspen Street	2nd Floor Addition	Michael Kurz	Bobby K Architects
6	8:40 p.m.	266	Whittier	Resubmittal Railing	Rajinder Kaur	M. Azeem PE

Questions about the projects can be emailed to ARB@FPVillage.org prior to the meeting to allow for the Village and Applicant to be prepared with answers.

Supporting documents will be posted to the Architectural Review Board web page at least 24 hours prior to the meeting.

Click [here](#) for the ARB webpage.

Case No.	Approximate Time	Address #	Street	Description	Owner	Design Professional
1	8:00 p.m.	7	Verbena Avenue	Re-submission - Sign	Shalini Tiwari	Dezant Signs Inc.

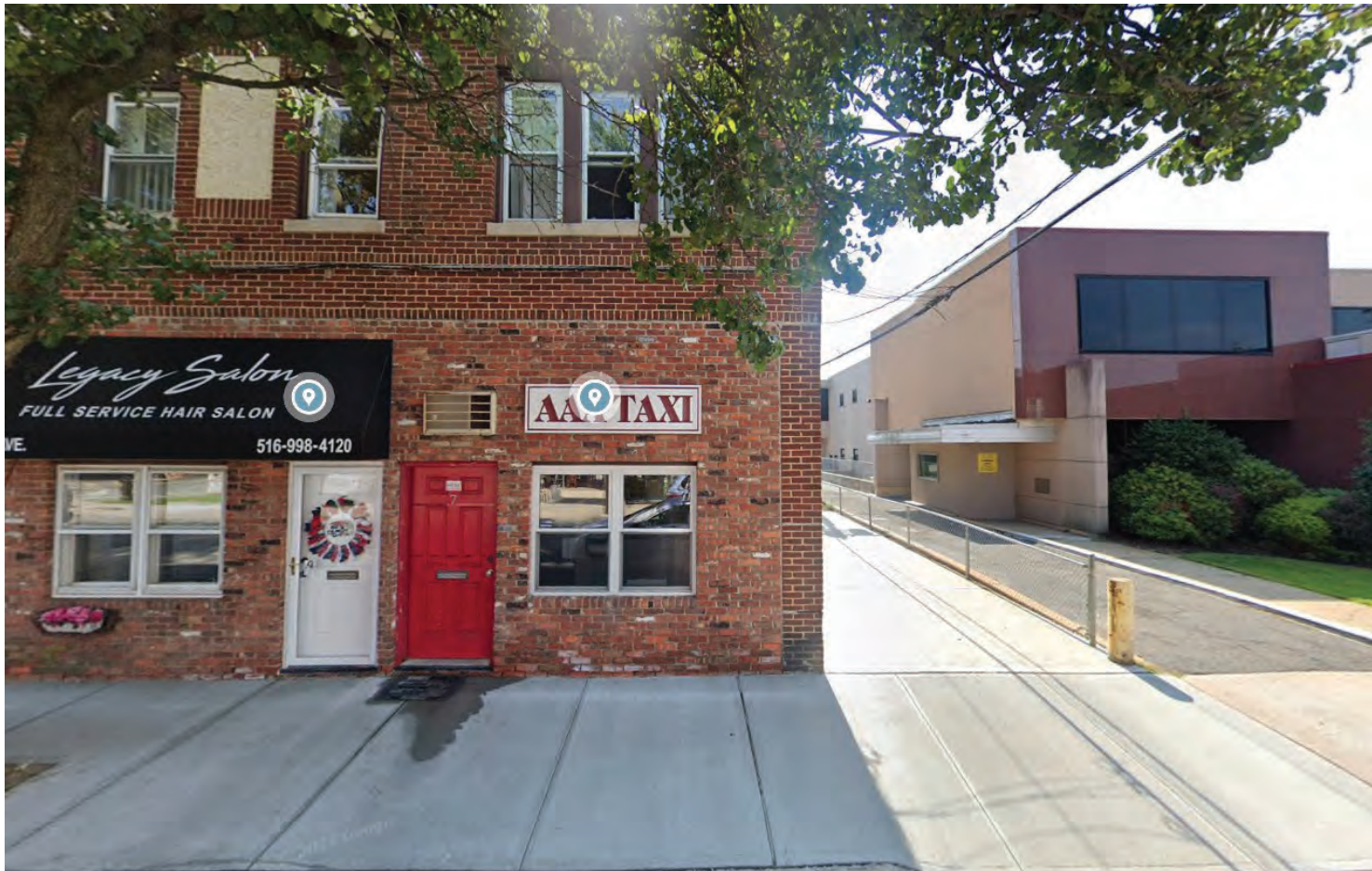

7 Verbena Avenue (Aerial View)

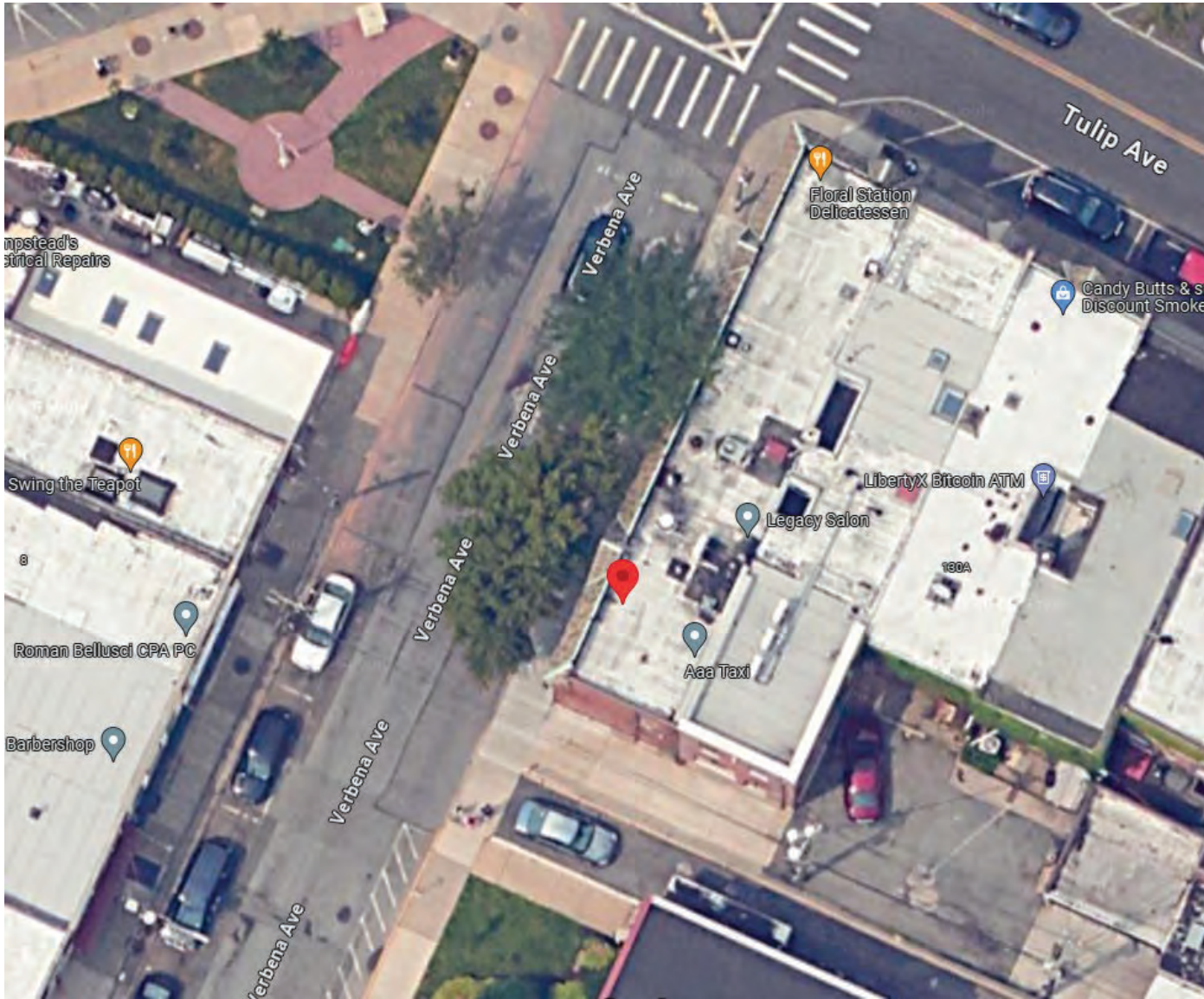

PREVIOUS SUBMISSION



6 ft.



2 ft.

1/2" acrylic letters

1" to 2" deep backer panel

DeZant

Signs & Printing

Design • Fabrication • Installation

Awnings, Light Boxes, Channel Letters,

Job-Site Signs, Wood Signs,

Truck Lettering & more

516-771-9241

32 Cherry Lane Floral Park, NY 11001

www.dezantsigns.com

PROPOSED SUBMISSION



6 ft.



2 ft.

1/2" acrylic letters

1" to 2" deep backer panel



Signs & Printing

Design • Fabrication • Installation

Awnings, Light Boxes, Channel Letters,
Job-Site Signs, Wood Signs,
Truck Lettering & more

516-771-9241

32 Cherry Lane Floral Park, NY 11001

www.dezantsigns.com

PREVIOUS SUBMISSION



6 ft.

B BODY BEAUTY AESTHETICS

1/2" acrylic letters
1" to 2" deep backer panel

2 ft.

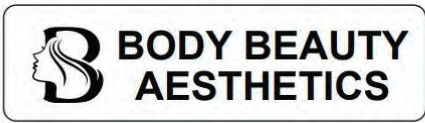

Dezant
Signs & Printing
Design • Fabrication • Installation
Awnings, Light Boxes, Channel Letters,
Job-Site Signs, Wood Signs,
Track Lettering & more

516-771-9241
32 Cherry Lane Floral Park, NY 11001

www.dezantsigns.com

PROPOSED SUBMISSION



6 ft.

B Body Beauty Aesthetics
516.279.4266



1/2" acrylic letters
1" to 2" deep backer panel

2 ft.



Dezant
Signs & Printing
Design • Fabrication • Installation
Awnings, Light Boxes, Channel Letters,
Job-Site Signs, Wood Signs,
Track Lettering & more

516-771-9241
32 Cherry Lane Floral Park, NY 11001

www.dezantsigns.com

Case No.	Approximate Time	Address #	Street	Description	Owner	Design Professional
2	8:05 p.m.	271	Jericho Turnpike	Sign	Ravin Patel	Dezant Signs Inc.

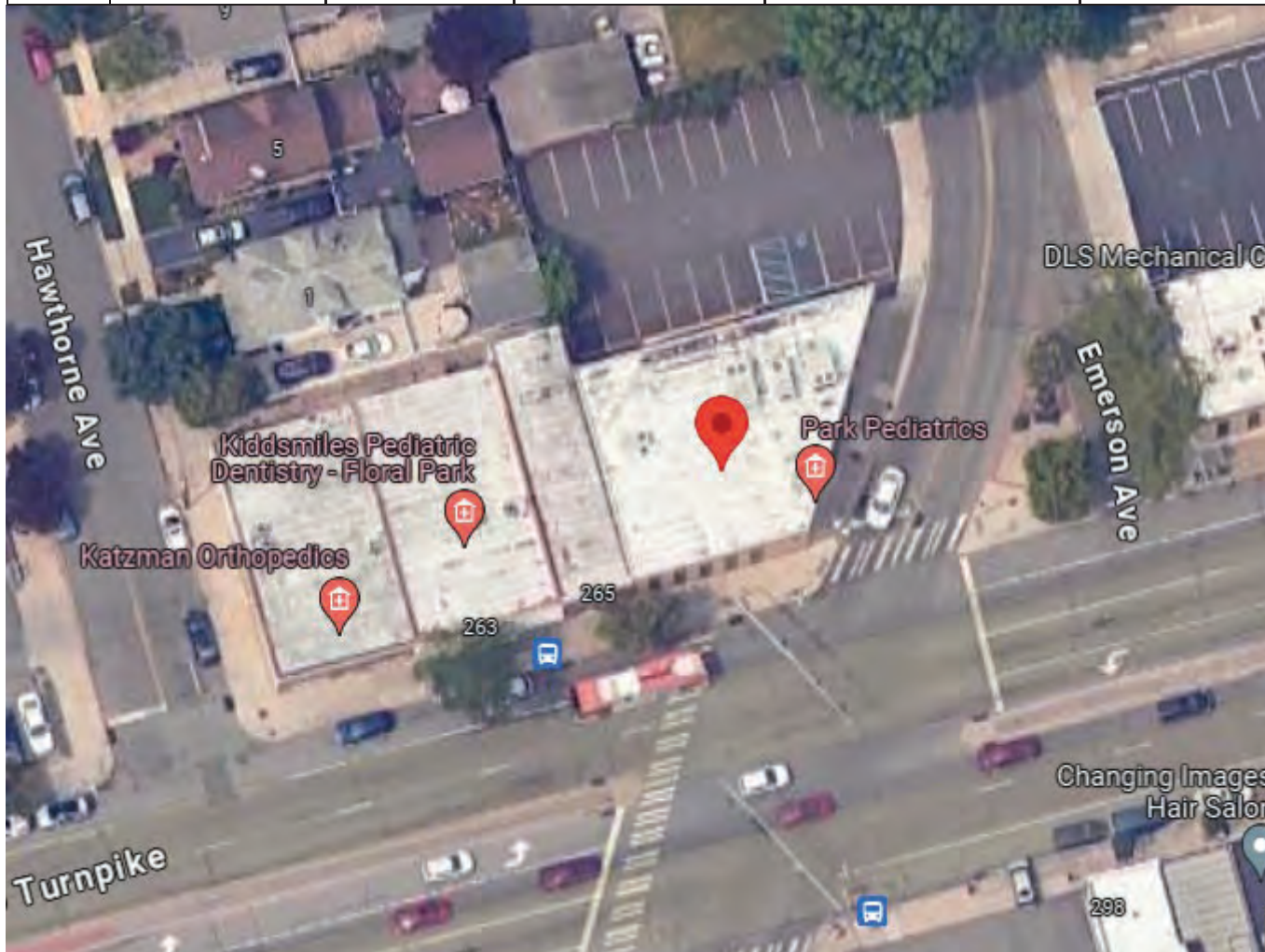

271 Jericho Turnpike



1 Emerson Ave

Floral Park, New York



Google Street View

Apr 2023

See more dates





96 in



28in

9in **FirstPoint**

16in **MD**

4in **— MEDICAL CENTER —**

DeZant

Signs & Printing

Design • Fabrication • Installation

Awnings, Light Boxes, Channel Letters,
Job-Site Signs, Wood Signs,
Truck Lettering & more

516-771-9241

32 Cherry Lane Floral Park, NY 11001

www.dezantsigns.com



96 in



DeZant

Signs & Printing

Design • Fabrication • Installation

Awnings, Light Boxes, Channel Letters,
Job-Site Signs, Wood Signs,
Truck Lettering & more

516-771-9241

32 Cherry Lane Floral Park, NY 11001

www.dezantsigns.com

Case No.	Approximate Time	Address #	Street	Description	Owner	Design Professional
3	8:10 p.m.	97	Emerson Avenue	Front Canopy and Stoop Reconstruction	Ryan Cummings	Demetris Demetriou



97 Emerson Avenue (Aerial View)

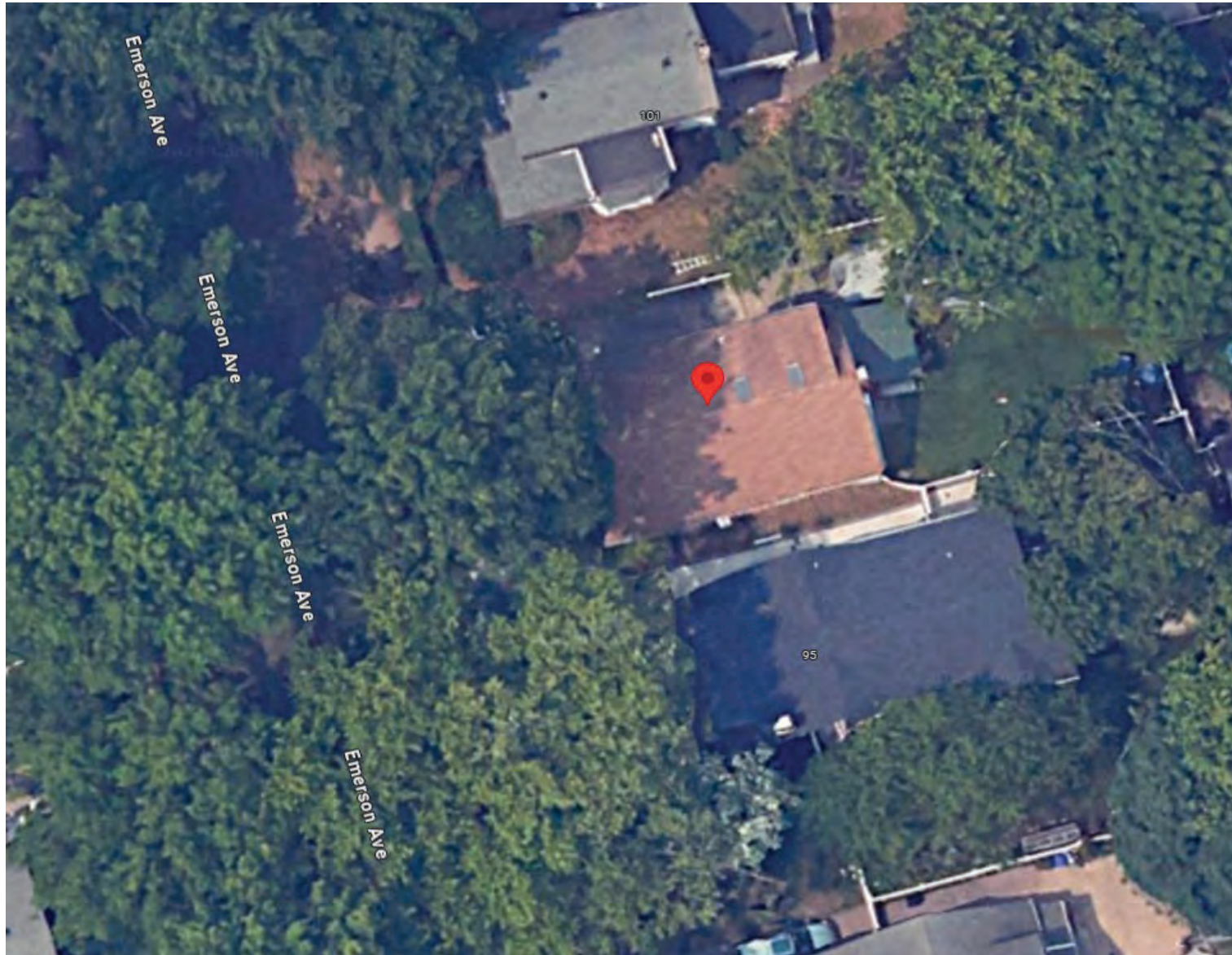



FRONT VIEW



LEFT SIDE

CUMMINGS RESIDENCE 97 EMERSON AVE., FLORAL PARK, NY 11001



RIGHT SIDE

CUMMINGS RESIDENCE 97 EMERSON AVE., FLORAL PARK, NY 11001



CUMMINGS RESIDENCE 97 EMERSON AVE., FLORAL PARK, NY 11001
with ADJACENT NEIGHBORS

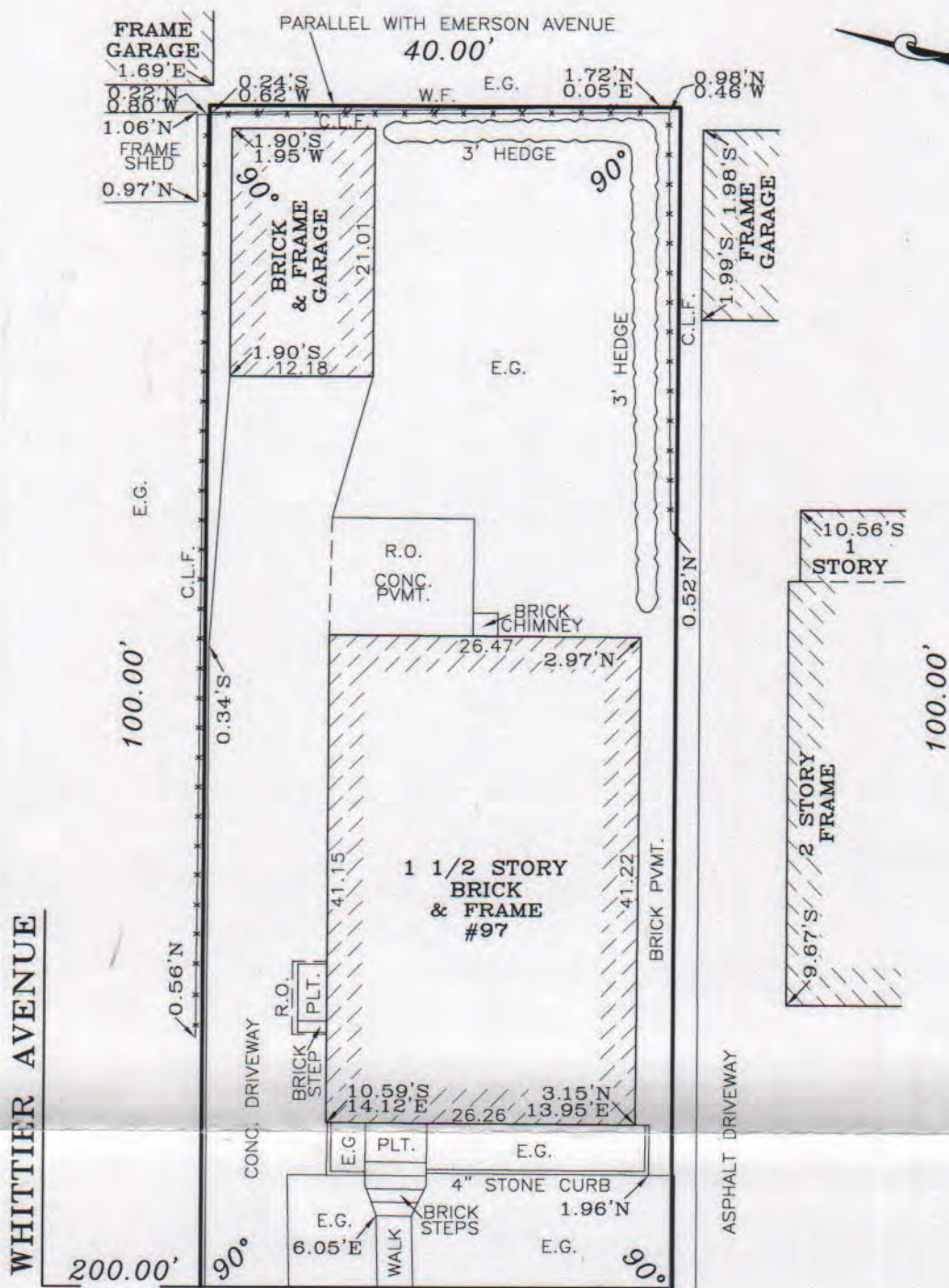

40.00'
EMERSON AVENUE

LEGEND:

- ROOF OVER — R.O.
- WOOD FENCE — W.F.
- EARTHEN GROUND — E.G.
- CONCRETE — CONC.
- PAVEMENT — PVMT.
- PLATFORM — PLT.
- CHAIN LINK FENCE — C.L.F.

FILED MAP:

ALL OF LOT 37 AND PART OF LOT 38, BLOCK Q, ON A CERTAIN MAP ENTITLED, "MAP OF THE MARGARET CUSTER CALHOUN SUBDIVISION, SITUATES AT FLORAL PARK IN THE TOWNS OF FLUSHING AND NORTH HEMPSTEAD QUEENS COUNTY NY. S.E., MINOR, GREENWICH, CONN. APRIL 1894" AND FILED IN THE OFFICE OF THE COUNTY OF QUEENS ON MAY 21, 1894 AS MAP NO. 1102 AND IN THE NASSAU COUNTY CLERK'S OFFICE AS OLD MAP NO. 29, NEW NO. 3109.

THE OFFSETS OR DIMENSIONS SHOWN FROM THE STRUCTURES TO THE PROPERTY LINES ARE FOR A SPECIFIC PURPOSE AND USE AND THEREFORE ARE NOT INTENDED TO GUIDE THE ERECTION OF FENCES, RETAINING WALLS, POOLS, PLANTING AREAS, ADDITIONS TO STRUCTURES AND ANY OTHER CONSTRUCTION.

THE EXISTENCE OF RIGHT OF WAYS AND/OR EASEMENTS OF RECORD, IF ANY, NOT SHOWN ARE NOT CERTIFIED.



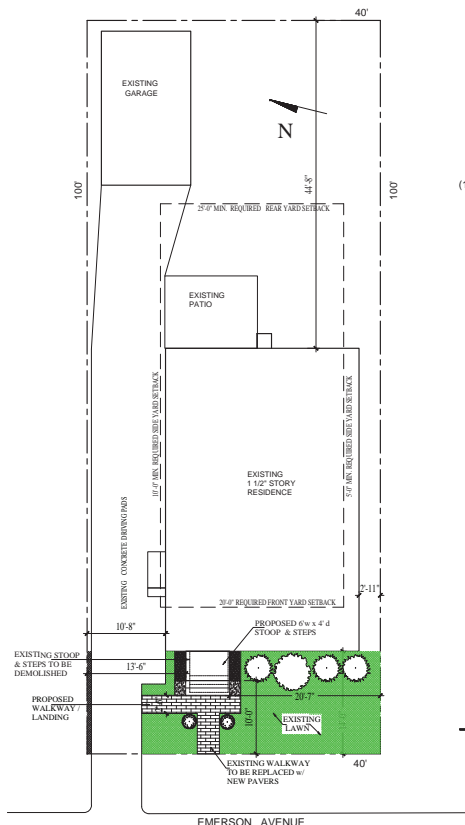

SITE PLAN
SCALE 1/4"=1'-0"

SITE PLAN INFORMATION TAKEN FROM SURVEY DRAWN BY LIC. SURVEYOR CHRISTOPHER M. BUCKLEY DATED: 6-25-2014

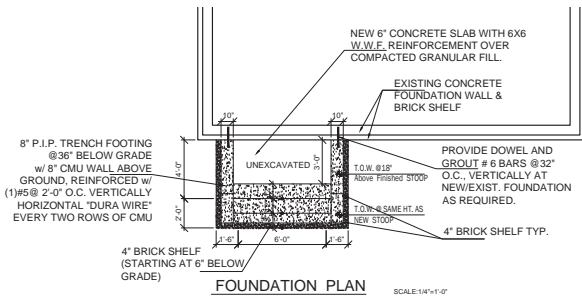

FOUNDATION PLAN
SCALE 1/4"=1'-0"

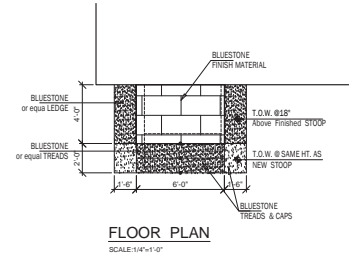

FLOOR PLAN
SCALE 1/4"=1'-0"



LEFT SIDE (N) ELEVATION
SCALE 3/8"=1'-0"

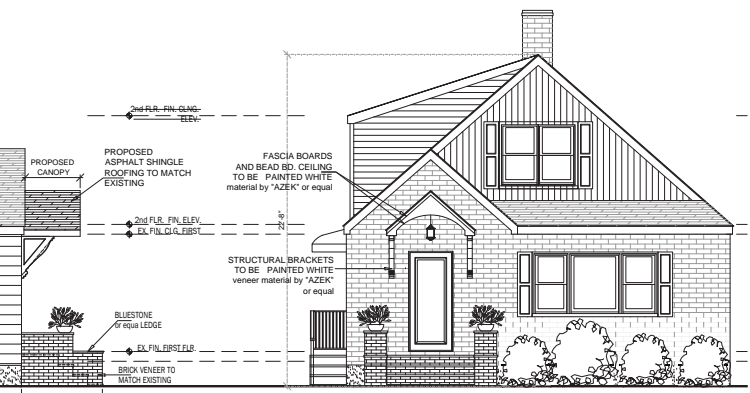

FRONT ELEVATION
SCALE 3/8"=1'-0"

	ALLOWED	PROPOSED
MAX. FRONT YARD COVERAGE	35% OF 600 sq.ft. ≈210 sq.ft.	210 sq.ft. = 35%

CODE COMPLIANCE:
TO THE BEST OF THE KNOWLEDGE, BELIEF, AND PROFESSIONAL JUDGMENT OF THE UNDERSIGNED, THE PLANS AND SPECIFICATIONS DEPICTED ON THESE DRAWINGS ARE IN COMPLIANCE WITH THE APPLICABLE PROVISIONS OF THE 2020 NEW YORK STATE UNIFORM FIRE PREVENTION AND BUILDING CODE AND ALL SUPPLEMENTS
COORDINATE ALL INSPECTIONS WITH THE LOCAL BUILDING DEPARTMENT

PERMITS REQUIRED:
ALL SPECIALTY WORK, SUCH AS PLUMBING, ELECTRICAL, MECHANICAL-HVAC & FIRE SPRINKLERS TO BE PERFORMED BY LICENSED CONTRACTORS AND OBTAIN REQUIRED PERMITS AS REQUIRED

EXCAVATION NOTE: GC. TO CALL 1(800)272-4480/811 PRIOR TO ANY EXCAVATION, TO RECEIVE A LIST OF ALL UNDERGROUND UTILITIES AND INDICATION FROM EACH OF THE PRESENT UTILITIES AT THE SITE.

ENERGY CODE:
TO THE BEST OF MY KNOWLEDGE, BELIEF AND PROFESSIONAL JUDGMENT, PLANS AND SPECIFICATIONS ARE IN COMPLIANCE WITH THE NYS ENERGY CODE.

GROUND LOAD	WIND DESIGN		WIND-BORN DEBRIS ZONE	SEISMIC DESIGN CATEGORY	SUBJECT TO DAMAGE FROM WEATHERING INDEX	FROST LINE DEPTH	TORNADO	WINTER DESIGN TEMP.	ICE BARRIER UNDERLAYMENT REQUIRED	FLOOD HAZARDS	AIR FREEZING INDEX	MEAN ANNUAL TEMPERATURE
	SPEED/MPH	SPEED/MPH										
20 psf	120 mph	NO	NO	B	SEVERE	3'-0"	MODERATE TO HEAVY	NASSAU: 13	YES	ZONE X	496	52.9

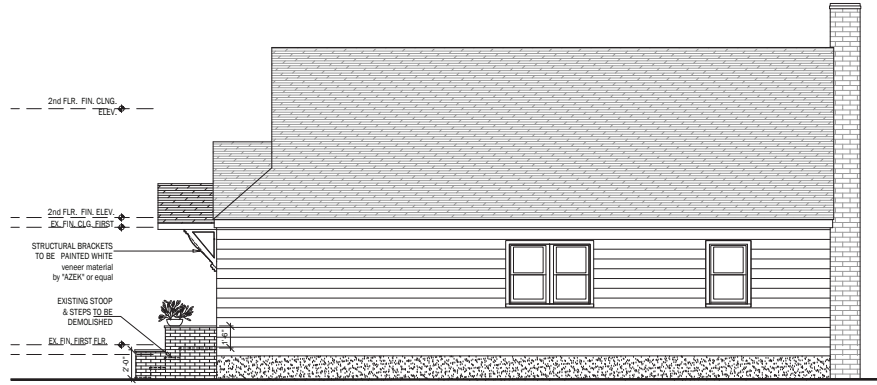

RIGHT SIDE (S) ELEVATION
SCALE 3/8"=1'-0"

- GENERAL NOTES:**
- ALL WORK SHALL CONFORM TO THE NEW YORK STATE, LOCAL AND ALL APPLICABLE CODES.
 - IT IS THE INTENTION OF THESE DRAWINGS TO PROVIDE FOR THE CONSTRUCTION OF A RESIDENCE INCLUDING EVERY ITEM AS SHOWN OR REASONABLY IMPLIED OR REQUIRED TO COMPLETE ALL WORK.
 - THE DRAWING AND NOTES ARE INTENDED TO BE COMPLETE. SHOULD ANYTHING BE OMITTED FROM THE DRAWINGS NECESSARY TO THE PROPER CONSTRUCTION OF THE WORK HEREIN DESCRIBED, IT SHALL BE THE DUTY OF THE CONTRACTOR TO NOTIFY THE ARCHITECT.
 - THE GENERAL CONTRACTOR SHALL VERIFY ALL DIMENSIONS IN FIELD. ANY DISCREPANCIES SHALL BE REPORTED TO THE ARCHITECT BEFORE PROCEEDING.
 - ONLY DRAWINGS APPROVED BY THE LOCAL BUILDING OFFICE IS TO BE USED FOR CONSTRUCTION PURPOSES.
 - ANY DISCREPANCIES IN THE PLANS, SPECIFICATIONS, DIMENSIONS, SIZES ETC. SHOULD BE BROUGHT TO THE ATTENTION OF THE ARCHITECT BEFORE PROCEEDING WITH THE WORK.
 - NO PLANS OR DRAWINGS ARE TO BE SCALED. ONLY DIMENSIONS SHOWN ARE TO BE USED.
 - NO PLANS OR DRAWINGS ARE TO BE SCALED. ONLY DIMENSIONS SHOWN ARE TO BE USED.
 - LICENSED ELECTRICIAN TO BE USED FOR ALL ELECTRICAL WORK.
 - LICENSED PLUMBER TO BE USED FOR ALL PLUMBING WORK.
 - CONTRACTOR TO VERIFY WITH OWNER AND UTILITY PROVIDERS THE LOCATIONS OF ANY UNDERGROUND UTILITIES, TANKS, PIPES OR LINES AND PROVIDE ADEQUATE PROTECTION AS NECESSARY.
 - CONTRACTOR IS RESPONSIBLE TO OBTAIN ALL NECESSARY INSPECTIONS TO OBTAIN CERTIFICATES OF OCCUPANCY/COMPLETION.
 - CONTRACTOR IS RESPONSIBLE FOR ALL CONSTRUCTION METHODS, TECHNIQUES, SEQUENCES AND FOR COORDINATING ALL TRADES TO COMPLETE WORK.
 - CONTRACTOR IS RESPONSIBLE TO LEAVE THE SITE AND SURROUNDING AREAS BROOM SWEEP CLEAN AT THE END OF EACH WORK DAY AND PREVENT THE ACCUMULATION OF WASTE AND DEBRIS ON THE CONSTRUCTION SITE.
 - CONTRACTOR IS RESPONSIBLE TO ERECT AND MAINTAIN REASONABLE SAFETY GUARDS AND PROTECTION OF THE SITE. THIS WILL INCLUDE FENCING, DANGER SIGNS AND OTHER WARNINGS.
 - THE ARCHITECT'S CERTIFICATION OF THE PLANS AND LIABILITY WITH THE WORK IS LIMITED TO THE PLANS CONFORMITY TO THE NEW YORK STATE UNIFORM FIRE AND PREVENTION AND BUILDING CODE.
 - CONTRACTOR IS RESPONSIBLE FOR ALL FABRICATED MATERIALS FOR ACCURACY, FIT AND INSTALLATION.
 - CONTRACTOR SHALL PROVIDE SHOP DRAWINGS FOR ACCEPTANCE FOR ALL FABRICATIONS AND FABRICATED MATERIALS.
 - CONTRACTOR TO COORDINATE WITH SMIPSON STRONG-ICE COMPANY, NO 1-800-899-5099 TO PROVIDE ALL CONSTRUCTION CONNECTIONS HANGERS AND BRACKETS AS REQUIRED FOR WIND RESISTANCE CONNECTIONS TO PROVIDE CONTINUOUS LOAD PATH FROM THE ROOF TO THE FOUNDATION.

DATE	REMARKS
6-5-2024	SUBMIT FOR A&E

DEMETRIS DEMETRIOU R.A.
5 GERARDUM AVE., FLORAL PARK, NY 11001
914.671.9907
ddemarchitect@gmail.com



FRONT ENTRY CANOPY, STOOP & STEPS

GADES RESIDENCE
60 WILLOW STREET
FLORAL PARK, NY 11001
SECTION:32, BLOCK:510, LOT: 124 & 125, ZONE: R-1

DATE: 6-5-2025
A-1



ROOFING by "TIMBERINE"
COLOR:"GOLDEN CEDAR"



FASCIA & TRIM by "AZEK"



BRICK & BLUESTONE

Case No.	Approximate Time	Address #	Street	Description	Owner	Design Professional
4	8:20 p.m.	286	Tulip Avenue	Sunroom Conversion	David Giesbrecht & Rachel Neville	Jeffrey Butler, PE



286 Tulip Avenue (Aerial View)



280 Tulip Avenue



290 Tulip Avenue



286 Tulip Avenue - Front



286 Tulip Avenue - Front



286 Tulip Avenue - Side



286 Tulip Avenue - Rear



286 Tulip Avenue - Rear/Side



286 Tulip Avenue - Garage Front



286 Tulip Avenue - Garage Side



TULIP AVENUE
(LIGHTHORSE ROAD)

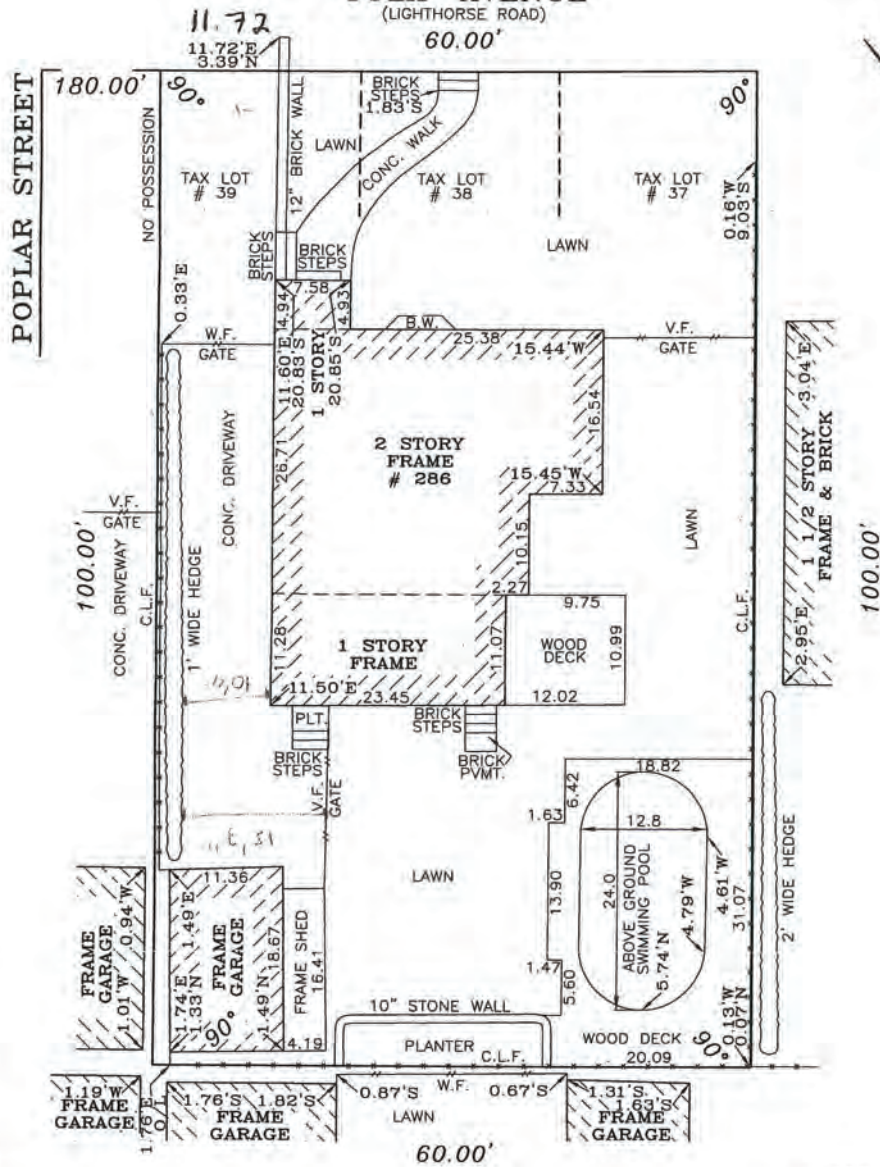

- LEGEND:
- BAY WINDOW — B.W.
 - CONCRETE — CONC.
 - PAVEMENT — PAVT.
 - PLATFORM — PLT.
 - CHAIN LINK FENCE — C.L.F.
 - VINYL FENCE — V.F.
 - WOOD FENCE — W.F.

TOTAL LOTS AREA IS 6000.0 sq.ft.
 TOTAL BUILDINGS AREA IS 1317.1 sq.ft.
 BUILDINGS AREA IS 21.9% OF LOT AREA
 FOR BUILDING DEPARTMENT USE ONLY
 AVERAGE FRONT YARD SETBACKS IS 19.6 FEET

THE OFFSETS OR DIMENSIONS SHOWN FROM THE STRUCTURES TO THE PROPERTY LINES ARE FOR A SPECIFIC PURPOSE AND USE AND THEREFORE ARE NOT INTENDED TO GUIDE THE ERECTION OF FENCES, RETAINING WALLS, POOLS, PLANTING AREAS, ADDITIONS TO STRUCTURES AND ANY OTHER CONSTRUCTION.

THE EXISTENCE OF RIGHT OF WAYS AND/OR EASEMENTS OF RECORD, IF ANY, NOT SHOWN ARE NOT CERTIFIED.



UNAUTHORIZED ALTERATION OR ADDITION TO THIS SURVEY IS A VIOLATION OF SECTION 7209 OF THE NEW YORK STATE EDUCATION LAW. COPIES OF THIS SURVEY MAP NOT BEARING THE LAND SURVEYOR'S INKED SEAL OR EMBOSSED SEAL SHALL NOT BE CONSIDERED TO BE A VALID TRUE COPY.

CERTIFICATION INDICATED HEREON SHALL RUN ONLY TO THE PERSON FOR WHOM THE SURVEY IS PREPARED, AND ON HIS BEHALF TO THE TITLE COMPANY, GOVERNMENTAL AGENCY AND LENDING INSTITUTION LISTED HEREON, AND TO THE ASSIGNEES OF THE LENDING INSTITUTION. CERTIFICATIONS ARE NOT TRANSFERABLE TO ADDITIONAL INSTITUTIONS OR SUBSEQUENT OWNERS.

PRECISION SURVEYS
 TITLE • ARCHITECTURAL • BOUNDARY • CONSTRUCTION
 40 FRANKLIN AVE. FRANKLIN SQUARE, N.Y. 11010
 Ph. • (718)472-1571 • (516)488-1608
CHRISTOPHER M. BUCKLEY
 PROFESSIONAL LAND SURVEYOR

SURVEY OF: Described Property

CERTIFIED TO:
Francis Lauria

LOCATED AT:
286 Tulip Avenue, Floral Park
County of Nassau
State of New York

TAX DESIG:
Sec. 32, Block 237, Lots 37, 38, 39

DATE: July 21, 2014
SCALE: 1"=15'

Job No. 34135
Drawn By: MK



Home > Products > Decking > TimberTech PRO® > Reserve Collection



TIMBERTECH COMPOSITE
Reserve Collection

Reclaimed Wood

Bring the charm of reclaimed wood to your space without the rigorous maintenance of wood. Featuring the rustic character and natural beauty of aged wood, our premium polymer capped composite boards deliver real wood aesthetics you'll never have to sand, stain, or seal.

COLOR: **ANTIQUE LEATHER**

SAMPLE SIZE

1' Sample

FREE \$0.00

V3 V1
SERIES SERIES

MainStreet™
Siding



Life happens here.



MainStreet is better...



STUOffinder™: Reduces 87% Chances of a particle and wood splintering & minimizes wood waste.

...for color availability.

3" Cleapboard WeatherShield	4" Cleapboard WeatherShield	5" Cleapboard WeatherShield	4" Dutchlap WeatherShield	5" Dutchlap WeatherShield	6-1/2" Beaded WeatherShield	8" Cleapboard WeatherShield	10" Cleapboard WeatherShield	12" Cleapboard WeatherShield	14" Cleapboard WeatherShield	16" Cleapboard WeatherShield	18" Cleapboard WeatherShield	20" Cleapboard WeatherShield	24" Cleapboard WeatherShield	30" Cleapboard WeatherShield	36" Cleapboard WeatherShield	42" Cleapboard WeatherShield	48" Cleapboard WeatherShield	60" Cleapboard WeatherShield	72" Cleapboard WeatherShield	84" Cleapboard WeatherShield	96" Cleapboard WeatherShield	108" Cleapboard WeatherShield	120" Cleapboard WeatherShield	144" Cleapboard WeatherShield	168" Cleapboard WeatherShield	192" Cleapboard WeatherShield	216" Cleapboard WeatherShield	240" Cleapboard WeatherShield	264" Cleapboard WeatherShield	288" Cleapboard WeatherShield	312" Cleapboard WeatherShield	336" Cleapboard WeatherShield	360" Cleapboard WeatherShield	384" Cleapboard WeatherShield	408" Cleapboard WeatherShield	432" Cleapboard WeatherShield	456" Cleapboard WeatherShield	480" Cleapboard WeatherShield	504" Cleapboard WeatherShield	528" Cleapboard WeatherShield	552" Cleapboard WeatherShield	576" Cleapboard WeatherShield	600" Cleapboard WeatherShield	624" Cleapboard WeatherShield	648" Cleapboard WeatherShield	672" Cleapboard WeatherShield	696" Cleapboard WeatherShield	720" Cleapboard WeatherShield	744" Cleapboard WeatherShield	768" Cleapboard WeatherShield	792" Cleapboard WeatherShield	816" Cleapboard WeatherShield	840" Cleapboard WeatherShield	864" Cleapboard WeatherShield	888" Cleapboard WeatherShield	912" Cleapboard WeatherShield	936" Cleapboard WeatherShield	960" Cleapboard WeatherShield	984" Cleapboard WeatherShield	1008" Cleapboard WeatherShield	1032" Cleapboard WeatherShield	1056" Cleapboard WeatherShield	1080" Cleapboard WeatherShield	1104" Cleapboard WeatherShield	1128" Cleapboard WeatherShield	1152" Cleapboard WeatherShield	1176" Cleapboard WeatherShield	1200" Cleapboard WeatherShield	1224" Cleapboard WeatherShield	1248" Cleapboard WeatherShield	1272" Cleapboard WeatherShield	1296" Cleapboard WeatherShield	1320" Cleapboard WeatherShield	1344" Cleapboard WeatherShield	1368" Cleapboard WeatherShield	1392" Cleapboard WeatherShield	1416" Cleapboard WeatherShield	1440" Cleapboard WeatherShield	1464" Cleapboard WeatherShield	1488" Cleapboard WeatherShield	1512" Cleapboard WeatherShield	1536" Cleapboard WeatherShield	1560" Cleapboard WeatherShield	1584" Cleapboard WeatherShield	1608" Cleapboard WeatherShield	1632" Cleapboard WeatherShield	1656" Cleapboard WeatherShield	1680" Cleapboard WeatherShield	1704" Cleapboard WeatherShield	1728" Cleapboard WeatherShield	1752" Cleapboard WeatherShield	1776" Cleapboard WeatherShield	1800" Cleapboard WeatherShield	1824" Cleapboard WeatherShield	1848" Cleapboard WeatherShield	1872" Cleapboard WeatherShield	1896" Cleapboard WeatherShield	1920" Cleapboard WeatherShield	1944" Cleapboard WeatherShield	1968" Cleapboard WeatherShield	1992" Cleapboard WeatherShield	2016" Cleapboard WeatherShield	2040" Cleapboard WeatherShield	2064" Cleapboard WeatherShield	2088" Cleapboard WeatherShield	2112" Cleapboard WeatherShield	2136" Cleapboard WeatherShield	2160" Cleapboard WeatherShield	2184" Cleapboard WeatherShield	2208" Cleapboard WeatherShield	2232" Cleapboard WeatherShield	2256" Cleapboard WeatherShield	2280" Cleapboard WeatherShield	2304" Cleapboard WeatherShield	2328" Cleapboard WeatherShield	2352" Cleapboard WeatherShield	2376" Cleapboard WeatherShield	2400" Cleapboard WeatherShield	2424" Cleapboard WeatherShield	2448" Cleapboard WeatherShield	2472" Cleapboard WeatherShield	2496" Cleapboard WeatherShield	2520" Cleapboard WeatherShield	2544" Cleapboard WeatherShield	2568" Cleapboard WeatherShield	2592" Cleapboard WeatherShield	2616" Cleapboard WeatherShield	2640" Cleapboard WeatherShield	2664" Cleapboard WeatherShield	2688" Cleapboard WeatherShield	2712" Cleapboard WeatherShield	2736" Cleapboard WeatherShield	2760" Cleapboard WeatherShield	2784" Cleapboard WeatherShield	2808" Cleapboard WeatherShield	2832" Cleapboard WeatherShield	2856" Cleapboard WeatherShield	2880" Cleapboard WeatherShield	2904" Cleapboard WeatherShield	2928" Cleapboard WeatherShield	2952" Cleapboard WeatherShield	2976" Cleapboard WeatherShield	3000" Cleapboard WeatherShield	3024" Cleapboard WeatherShield	3048" Cleapboard WeatherShield	3072" Cleapboard WeatherShield	3096" Cleapboard WeatherShield	3120" Cleapboard WeatherShield	3144" Cleapboard WeatherShield	3168" Cleapboard WeatherShield	3192" Cleapboard WeatherShield	3216" Cleapboard WeatherShield	3240" Cleapboard WeatherShield	3264" Cleapboard WeatherShield	3288" Cleapboard WeatherShield	3312" Cleapboard WeatherShield	3336" Cleapboard WeatherShield	3360" Cleapboard WeatherShield	3384" Cleapboard WeatherShield	3408" Cleapboard WeatherShield	3432" Cleapboard WeatherShield	3456" Cleapboard WeatherShield	3480" Cleapboard WeatherShield	3504" Cleapboard WeatherShield	3528" Cleapboard WeatherShield	3552" Cleapboard WeatherShield	3576" Cleapboard WeatherShield	3600" Cleapboard WeatherShield	3624" Cleapboard WeatherShield	3648" Cleapboard WeatherShield	3672" Cleapboard WeatherShield	3696" Cleapboard WeatherShield	3720" Cleapboard WeatherShield	3744" Cleapboard WeatherShield	3768" Cleapboard WeatherShield	3792" Cleapboard WeatherShield	3816" Cleapboard WeatherShield	3840" Cleapboard WeatherShield	3864" Cleapboard WeatherShield	3888" Cleapboard WeatherShield	3912" Cleapboard WeatherShield	3936" Cleapboard WeatherShield	3960" Cleapboard WeatherShield	3984" Cleapboard WeatherShield	4008" Cleapboard WeatherShield	4032" Cleapboard WeatherShield	4056" Cleapboard WeatherShield	4080" Cleapboard WeatherShield	4104" Cleapboard WeatherShield	4128" Cleapboard WeatherShield	4152" Cleapboard WeatherShield	4176" Cleapboard WeatherShield	4200" Cleapboard WeatherShield	4224" Cleapboard WeatherShield	4248" Cleapboard WeatherShield	4272" Cleapboard WeatherShield	4296" Cleapboard WeatherShield	4320" Cleapboard WeatherShield	4344" Cleapboard WeatherShield	4368" Cleapboard WeatherShield	4392" Cleapboard WeatherShield	4416" Cleapboard WeatherShield	4440" Cleapboard WeatherShield	4464" Cleapboard WeatherShield	4488" Cleapboard WeatherShield	4512" Cleapboard WeatherShield	4536" Cleapboard WeatherShield	4560" Cleapboard WeatherShield	4584" Cleapboard WeatherShield	4608" Cleapboard WeatherShield	4632" Cleapboard WeatherShield	4656" Cleapboard WeatherShield	4680" Cleapboard WeatherShield	4704" Cleapboard WeatherShield	4728" Cleapboard WeatherShield	4752" Cleapboard WeatherShield	4776" Cleapboard WeatherShield	4800" Cleapboard WeatherShield	4824" Cleapboard WeatherShield	4848" Cleapboard WeatherShield	4872" Cleapboard WeatherShield	4896" Cleapboard WeatherShield	4920" Cleapboard WeatherShield	4944" Cleapboard WeatherShield	4968" Cleapboard WeatherShield	4992" Cleapboard WeatherShield	5016" Cleapboard WeatherShield	5040" Cleapboard WeatherShield	5064" Cleapboard WeatherShield	5088" Cleapboard WeatherShield	5112" Cleapboard WeatherShield	5136" Cleapboard WeatherShield	5160" Cleapboard WeatherShield	5184" Cleapboard WeatherShield	5208" Cleapboard WeatherShield	5232" Cleapboard WeatherShield	5256" Cleapboard WeatherShield	5280" Cleapboard WeatherShield	5304" Cleapboard WeatherShield	5328" Cleapboard WeatherShield	5352" Cleapboard WeatherShield	5376" Cleapboard WeatherShield	5400" Cleapboard WeatherShield	5424" Cleapboard WeatherShield	5448" Cleapboard WeatherShield	5472" Cleapboard WeatherShield	5496" Cleapboard WeatherShield	5520" Cleapboard WeatherShield	5544" Cleapboard WeatherShield	5568" Cleapboard WeatherShield	5592" Cleapboard WeatherShield	5616" Cleapboard WeatherShield	5640" Cleapboard WeatherShield	5664" Cleapboard WeatherShield	5688" Cleapboard WeatherShield	5712" Cleapboard WeatherShield	5736" Cleapboard WeatherShield	5760" Cleapboard WeatherShield	5784" Cleapboard WeatherShield	5808" Cleapboard WeatherShield	5832" Cleapboard WeatherShield	5856" Cleapboard WeatherShield	5880" Cleapboard WeatherShield	5904" Cleapboard WeatherShield	5928" Cleapboard WeatherShield	5952" Cleapboard WeatherShield	5976" Cleapboard WeatherShield	6000" Cleapboard WeatherShield	6024" Cleapboard WeatherShield	6048" Cleapboard WeatherShield	6072" Cleapboard WeatherShield	6096" Cleapboard WeatherShield	6120" Cleapboard WeatherShield	6144" Cleapboard WeatherShield	6168" Cleapboard WeatherShield	6192" Cleapboard WeatherShield	6216" Cleapboard WeatherShield	6240" Cleapboard WeatherShield	6264" Cleapboard WeatherShield	6288" Cleapboard WeatherShield	6312" Cleapboard WeatherShield	6336" Cleapboard WeatherShield	6360" Cleapboard WeatherShield	6384" Cleapboard WeatherShield	6408" Cleapboard WeatherShield	6432" Cleapboard WeatherShield	6456" Cleapboard WeatherShield	6480" Cleapboard WeatherShield	6504" Cleapboard WeatherShield	6528" Cleapboard WeatherShield	6552" Cleapboard WeatherShield	6576" Cleapboard WeatherShield	6600" Cleapboard WeatherShield	6624" Cleapboard WeatherShield	6648" Cleapboard WeatherShield	6672" Cleapboard WeatherShield	6696" Cleapboard WeatherShield	6720" Cleapboard WeatherShield	6744" Cleapboard WeatherShield	6768" Cleapboard WeatherShield	6792" Cleapboard WeatherShield	6816" Cleapboard WeatherShield	6840" Cleapboard WeatherShield	6864" Cleapboard WeatherShield	6888" Cleapboard WeatherShield	6912" Cleapboard WeatherShield	6936" Cleapboard WeatherShield	6960" Cleapboard WeatherShield	6984" Cleapboard WeatherShield	7008" Cleapboard WeatherShield	7032" Cleapboard WeatherShield	7056" Cleapboard WeatherShield	7080" Cleapboard WeatherShield	7104" Cleapboard WeatherShield	7128" Cleapboard WeatherShield	7152" Cleapboard WeatherShield	7176" Cleapboard WeatherShield	7200" Cleapboard WeatherShield	7224" Cleapboard WeatherShield	7248" Cleapboard WeatherShield	7272" Cleapboard WeatherShield	7296" Cleapboard WeatherShield	7320" Cleapboard WeatherShield	7344" Cleapboard WeatherShield	7368" Cleapboard WeatherShield	7392" Cleapboard WeatherShield	7416" Cleapboard WeatherShield	7440" Cleapboard WeatherShield	7464" Cleapboard WeatherShield	7488" Cleapboard WeatherShield	7512" Cleapboard WeatherShield	7536" Cleapboard WeatherShield	7560" Cleapboard WeatherShield	7584" Cleapboard WeatherShield	7608" Cleapboard WeatherShield	7632" Cleapboard WeatherShield	7656" Cleapboard WeatherShield	7680" Cleapboard WeatherShield	7704" Cleapboard WeatherShield	7728" Cleapboard WeatherShield	7752" Cleapboard WeatherShield	7776" Cleapboard WeatherShield	7800" Cleapboard WeatherShield	7824" Cleapboard WeatherShield	7848" Cleapboard WeatherShield	7872" Cleapboard WeatherShield	7896" Cleapboard WeatherShield	7920" Cleapboard WeatherShield	7944" Cleapboard WeatherShield	7968" Cleapboard WeatherShield	7992" Cleapboard WeatherShield	8016" Cleapboard WeatherShield	8040" Cleapboard WeatherShield	8064" Cleapboard WeatherShield	8088" Cleapboard WeatherShield	8112" Cleapboard WeatherShield	8136" Cleapboard WeatherShield	8160" Cleapboard WeatherShield	8184" Cleapboard WeatherShield	8208" Cleapboard WeatherShield	8232" Cleapboard WeatherShield	8256" Cleapboard WeatherShield	8280" Cleapboard WeatherShield	8304" Cleapboard WeatherShield	8328" Cleapboard WeatherShield	8352" Cleapboard WeatherShield	8376" Cleapboard WeatherShield	8400" Cleapboard WeatherShield	8424" Cleapboard WeatherShield	8448" Cleapboard WeatherShield	8472" Cleapboard WeatherShield	8496" Cleapboard WeatherShield	8520" Cleapboard WeatherShield	8544" Cleapboard WeatherShield	8568" Cleapboard WeatherShield	8592" Cleapboard WeatherShield	8616" Cleapboard WeatherShield	8640" Cleapboard WeatherShield	8664" Cleapboard WeatherShield	8688" Cleapboard WeatherShield	8712" Cleapboard WeatherShield	8736" Cleapboard WeatherShield	8760" Cleapboard WeatherShield	8784" Cleapboard WeatherShield	8808" Cleapboard WeatherShield	8832" Cleapboard WeatherShield	8856" Cleapboard WeatherShield	8880" Cleapboard WeatherShield	8904" Cleapboard WeatherShield	8928" Cleapboard WeatherShield	8952" Cleapboard WeatherShield	8976" Cleapboard WeatherShield	9000" Cleapboard WeatherShield	9024" Cleapboard WeatherShield	9048" Cleapboard WeatherShield	9072" Cleapboard WeatherShield	9096" Cleapboard WeatherShield	9120" Cleapboard WeatherShield	9144" Cleapboard WeatherShield	9168" Cleapboard WeatherShield	9192" Cleapboard WeatherShield	9216" Cleapboard WeatherShield	9240" Cleapboard WeatherShield	9264" Cleapboard WeatherShield	9288" Cleapboard WeatherShield	9312" Cleapboard WeatherShield	9336" Cleapboard WeatherShield	9360" Cleapboard WeatherShield	9384" Cleapboard WeatherShield	9408" Cleapboard WeatherShield	9432" Cleapboard WeatherShield	9456" Cleapboard WeatherShield	9480" Cleapboard WeatherShield	9504" Cleapboard WeatherShield	9528" Cleapboard WeatherShield	9552" Cleapboard WeatherShield	9576" Cleapboard WeatherShield	9600" Cleapboard WeatherShield	9624" Cleapboard WeatherShield	9648" Cleapboard WeatherShield	9672" Cleapboard WeatherShield	9696" Cleapboard WeatherShield	9720" Cleapboard WeatherShield	9744" Cleapboard WeatherShield	9768" Cleapboard WeatherShield	9792" Cleapboard WeatherShield	9816" Cleapboard WeatherShield	9840" Cleapboard WeatherShield	9864" Cleapboard WeatherShield	9888" Cleapboard WeatherShield	9912" Cleapboard WeatherShield	9936" Cleapboard WeatherShield	9960" Cleapboard WeatherShield	9984" Cleapboard WeatherShield	10008" Cleapboard WeatherShield
--------------------------------	--------------------------------	--------------------------------	------------------------------	------------------------------	--------------------------------	--------------------------------	---------------------------------	---------------------------------	---------------------------------	---------------------------------	---------------------------------	---------------------------------	---------------------------------	---------------------------------	---------------------------------	---------------------------------	---------------------------------	---------------------------------	---------------------------------	---------------------------------	---------------------------------	----------------------------------	----------------------------------	----------------------------------	----------------------------------	----------------------------------	----------------------------------	----------------------------------	----------------------------------	----------------------------------	----------------------------------	----------------------------------	----------------------------------	----------------------------------	----------------------------------	----------------------------------	----------------------------------	----------------------------------	----------------------------------	----------------------------------	----------------------------------	----------------------------------	----------------------------------	----------------------------------	----------------------------------	----------------------------------	----------------------------------	----------------------------------	----------------------------------	----------------------------------	----------------------------------	----------------------------------	----------------------------------	----------------------------------	----------------------------------	----------------------------------	----------------------------------	----------------------------------	----------------------------------	-----------------------------------	-----------------------------------	-----------------------------------	-----------------------------------	-----------------------------------	-----------------------------------	-----------------------------------	-----------------------------------	-----------------------------------	-----------------------------------	-----------------------------------	-----------------------------------	-----------------------------------	-----------------------------------	-----------------------------------	-----------------------------------	-----------------------------------	-----------------------------------	-----------------------------------	-----------------------------------	-----------------------------------	-----------------------------------	-----------------------------------	-----------------------------------	-----------------------------------	-----------------------------------	-----------------------------------	-----------------------------------	-----------------------------------	-----------------------------------	-----------------------------------	-----------------------------------	-----------------------------------	-----------------------------------	-----------------------------------	-----------------------------------	-----------------------------------	-----------------------------------	-----------------------------------	-----------------------------------	-----------------------------------	-----------------------------------	-----------------------------------	-----------------------------------	-----------------------------------	-----------------------------------	-----------------------------------	-----------------------------------	-----------------------------------	-----------------------------------	-----------------------------------	-----------------------------------	-----------------------------------	-----------------------------------	-----------------------------------	-----------------------------------	-----------------------------------	-----------------------------------	-----------------------------------	-----------------------------------	-----------------------------------	-----------------------------------	-----------------------------------	-----------------------------------	-----------------------------------	-----------------------------------	-----------------------------------	-----------------------------------	-----------------------------------	-----------------------------------	-----------------------------------	-----------------------------------	-----------------------------------	-----------------------------------	-----------------------------------	-----------------------------------	-----------------------------------	-----------------------------------	-----------------------------------	-----------------------------------	-----------------------------------	-----------------------------------	-----------------------------------	-----------------------------------	-----------------------------------	-----------------------------------	-----------------------------------	-----------------------------------	-----------------------------------	-----------------------------------	-----------------------------------	-----------------------------------	-----------------------------------	-----------------------------------	-----------------------------------	-----------------------------------	-----------------------------------	-----------------------------------	-----------------------------------	-----------------------------------	-----------------------------------	-----------------------------------	-----------------------------------	-----------------------------------	-----------------------------------	-----------------------------------	-----------------------------------	-----------------------------------	-----------------------------------	-----------------------------------	-----------------------------------	-----------------------------------	-----------------------------------	-----------------------------------	-----------------------------------	-----------------------------------	-----------------------------------	-----------------------------------	-----------------------------------	-----------------------------------	-----------------------------------	-----------------------------------	-----------------------------------	-----------------------------------	-----------------------------------	-----------------------------------	-----------------------------------	-----------------------------------	-----------------------------------	-----------------------------------	-----------------------------------	-----------------------------------	-----------------------------------	-----------------------------------	-----------------------------------	-----------------------------------	-----------------------------------	-----------------------------------	-----------------------------------	-----------------------------------	-----------------------------------	-----------------------------------	-----------------------------------	-----------------------------------	-----------------------------------	-----------------------------------	-----------------------------------	-----------------------------------	-----------------------------------	-----------------------------------	-----------------------------------	-----------------------------------	-----------------------------------	-----------------------------------	-----------------------------------	-----------------------------------	-----------------------------------	-----------------------------------	-----------------------------------	-----------------------------------	-----------------------------------	-----------------------------------	-----------------------------------	-----------------------------------	-----------------------------------	-----------------------------------	-----------------------------------	-----------------------------------	-----------------------------------	-----------------------------------	-----------------------------------	-----------------------------------	-----------------------------------	-----------------------------------	-----------------------------------	-----------------------------------	-----------------------------------	-----------------------------------	-----------------------------------	-----------------------------------	-----------------------------------	-----------------------------------	-----------------------------------	-----------------------------------	-----------------------------------	-----------------------------------	-----------------------------------	-----------------------------------	-----------------------------------	-----------------------------------	-----------------------------------	-----------------------------------	-----------------------------------	-----------------------------------	-----------------------------------	-----------------------------------	-----------------------------------	-----------------------------------	-----------------------------------	-----------------------------------	-----------------------------------	-----------------------------------	-----------------------------------	-----------------------------------	-----------------------------------	-----------------------------------	-----------------------------------	-----------------------------------	-----------------------------------	-----------------------------------	-----------------------------------	-----------------------------------	-----------------------------------	-----------------------------------	-----------------------------------	-----------------------------------	-----------------------------------	-----------------------------------	-----------------------------------	-----------------------------------	-----------------------------------	-----------------------------------	-----------------------------------	-----------------------------------	-----------------------------------	-----------------------------------	-----------------------------------	-----------------------------------	-----------------------------------	-----------------------------------	-----------------------------------	-----------------------------------	-----------------------------------	-----------------------------------	-----------------------------------	-----------------------------------	-----------------------------------	-----------------------------------	-----------------------------------	-----------------------------------	-----------------------------------	-----------------------------------	-----------------------------------	-----------------------------------	-----------------------------------	-----------------------------------	-----------------------------------	-----------------------------------	-----------------------------------	-----------------------------------	-----------------------------------	-----------------------------------	-----------------------------------	-----------------------------------	-----------------------------------	-----------------------------------	-----------------------------------	-----------------------------------	-----------------------------------	-----------------------------------	-----------------------------------	-----------------------------------	-----------------------------------	-----------------------------------	-----------------------------------	-----------------------------------	-----------------------------------	-----------------------------------	-----------------------------------	-----------------------------------	-----------------------------------	-----------------------------------	-----------------------------------	-----------------------------------	-----------------------------------	-----------------------------------	-----------------------------------	-----------------------------------	-----------------------------------	-----------------------------------	-----------------------------------	-----------------------------------	-----------------------------------	-----------------------------------	-----------------------------------	-----------------------------------	-----------------------------------	-----------------------------------	-----------------------------------	-----------------------------------	-----------------------------------	-----------------------------------	-----------------------------------	-----------------------------------	-----------------------------------	-----------------------------------	-----------------------------------	-----------------------------------	-----------------------------------	-----------------------------------	-----------------------------------	-----------------------------------	-----------------------------------	-----------------------------------	-----------------------------------	-----------------------------------	-----------------------------------	-----------------------------------	-----------------------------------	-----------------------------------	-----------------------------------	-----------------------------------	-----------------------------------	-----------------------------------	-----------------------------------	-----------------------------------	-----------------------------------	-----------------------------------	-----------------------------------	-----------------------------------	-----------------------------------	-----------------------------------	-----------------------------------	-----------------------------------	-----------------------------------	-----------------------------------	-----------------------------------	-----------------------------------	-----------------------------------	-----------------------------------	-----------------------------------	-----------------------------------	-----------------------------------	-----------------------------------	-----------------------------------	-----------------------------------	-----------------------------------	-----------------------------------	-----------------------------------	-----------------------------------	-----------------------------------	-----------------------------------	-----------------------------------	-----------------------------------	-----------------------------------	-----------------------------------	-----------------------------------	-----------------------------------	-----------------------------------	-----------------------------------	-----------------------------------	-----------------------------------	-----------------------------------	-----------------------------------	-----------------------------------	-----------------------------------	-----------------------------------	-----------------------------------	-----------------------------------	-----------------------------------	-----------------------------------	-----------------------------------	-----------------------------------	-----------------------------------	-----------------------------------	-----------------------------------	-----------------------------------	-----------------------------------	-----------------------------------	-----------------------------------	-----------------------------------	-----------------------------------	-----------------------------------	-----------------------------------	-----------------------------------	------------------------------------

...for safety.

STUOffinder™ is an installation system with slotters on the MainStreet's panel wall beam to ensure proper nailing to wood studs. To protect you from unwanted dangers such as damaged pipes or wires, or exposed nails.



...for protection.

When installed with MainStreet siding, Certainteed Weather Resistant Barrier is the added layer of protection against air and moisture damage.

...for peace of mind.

- Warranty**
MainStreet has a lifetime limited warranty.
- Trusted Brand**
Certainteed siding is the brand preferred by building professionals and homeowners, from surveys conducted by national trade magazines. Certainteed is an industry leader for over 100 years.
- Sustainable**
Certainteed vinyl siding offers significantly lower environmental impact than other cladding options.

Long-Lasting Colors

PermaCOLOR™ System assures color performance, resistance and durability. Utilizing the newest technology and state-of-the-art formulations, Certainteed backs their vinyl siding with PermaCOLOR Lifetime Fade Protection.

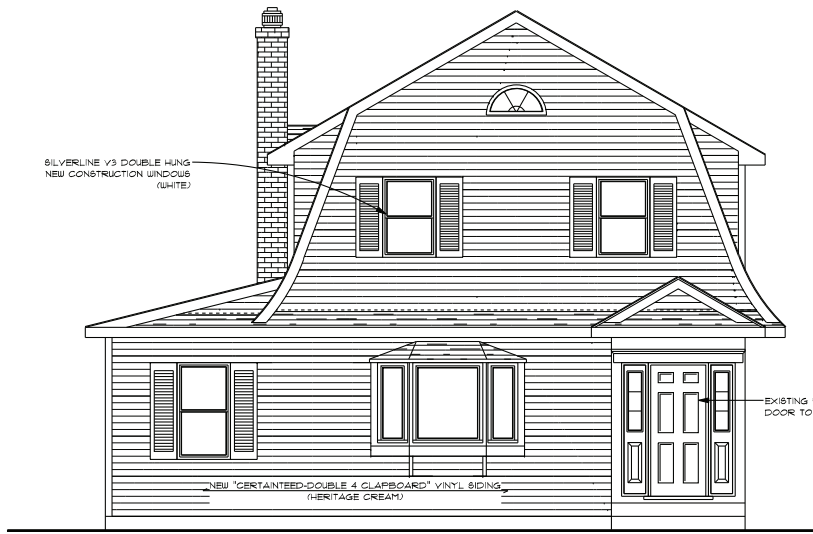

FRONT ELEVATION

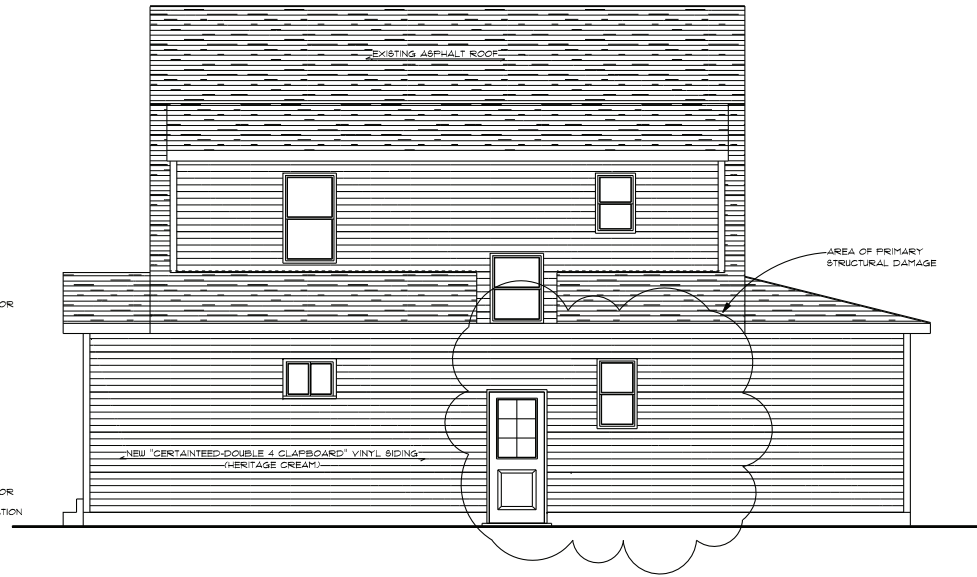
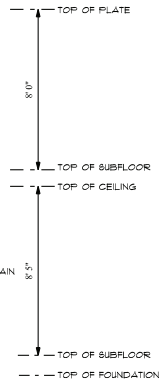

RIGHT SIDE ELEVATION



LEFT SIDE ELEVATION

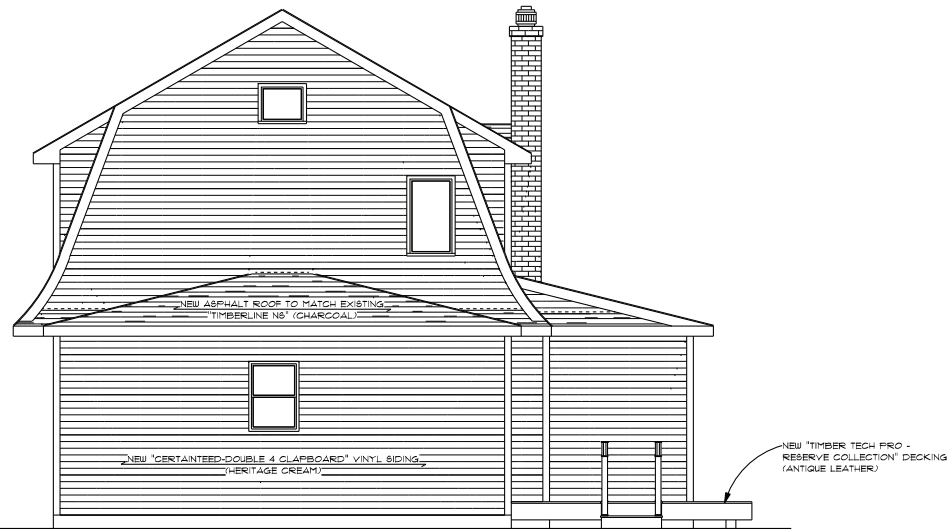
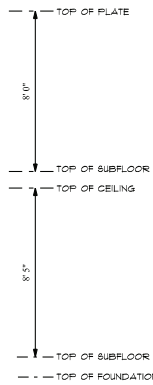

REAR ELEVATION

STEP 6 PER CODE
 CONTRACTOR TO PROVIDE RAIL
 PER CODE WHERE ELEVATION CHANGE
 IS GREATER THAN 30" PER 2020 NYS CODE

EAVE DETAIL

14" DIA x MIN 36" DEEP
OR TO UNDISTURBED SOIL
P.C. PIER WITH 6x6 ACQ
POST TO DECK GIRDER.
ANCHOR PER DETAIL
SHEET, TYP.

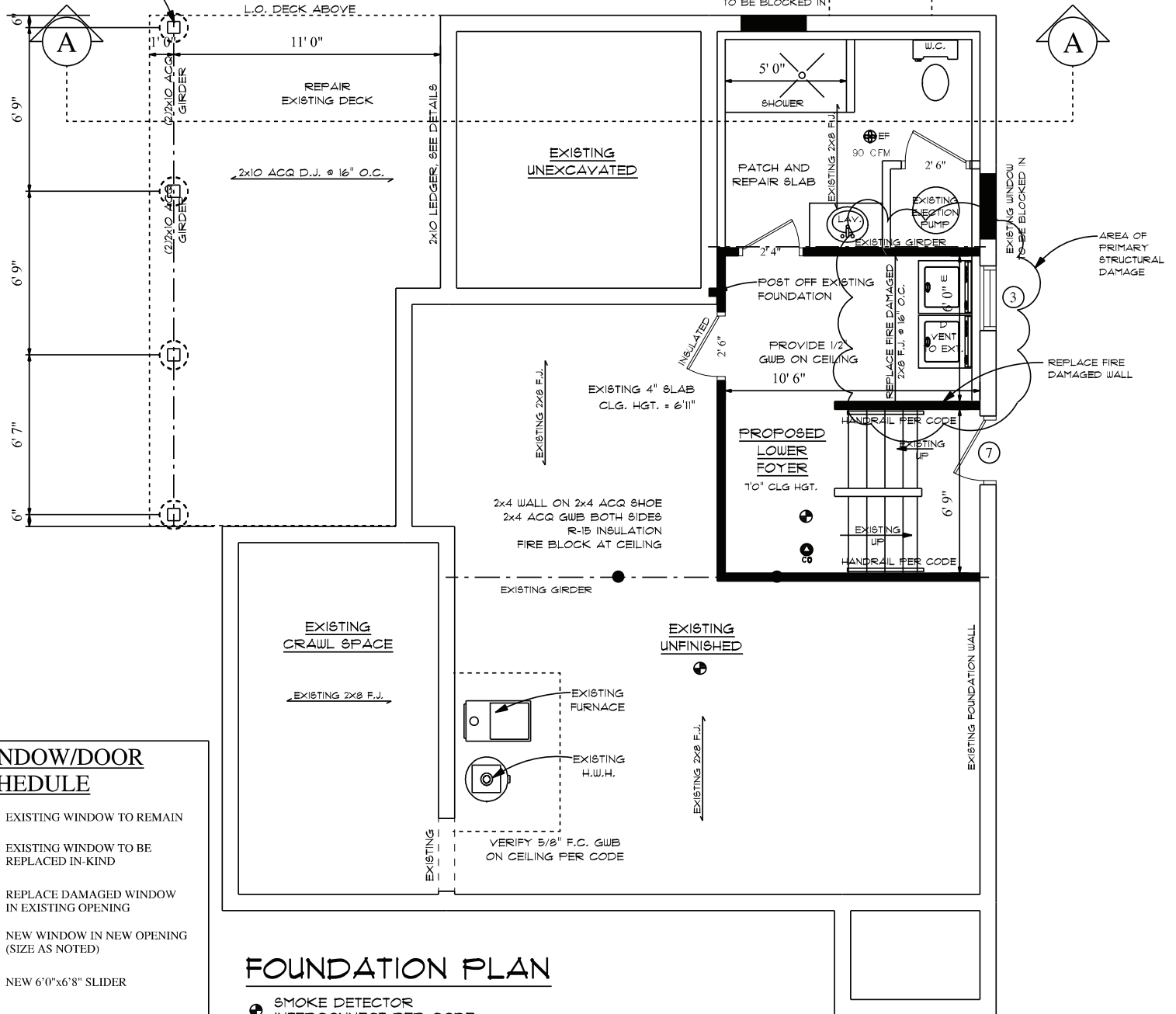

S
LE R507.2

DISTRIBUTED
MIN 24" OF EACH
DOWN DEVICES
K JOIST PER
ER.

METER LAG
3" PENETRATION
TUDS, OR HEADER

WINDOW/DOOR SCHEDULE

- ① EXISTING WINDOW TO REMAIN
- ② EXISTING WINDOW TO BE REPLACED IN-KIND
- ③ REPLACE DAMAGED WINDOW IN EXISTING OPENING
- ④ NEW WINDOW IN NEW OPENING (SIZE AS NOTED)
- ⑤ NEW 6'0"x6'8" SLIDER
- ⑥ EXISTING DOOR TO REMAIN
- ⑦ REPLACE DAMAGED DOOR IN EXISTING OPENING

FOUNDATION PLAN

- ⊕ SMOKE DETECTOR INTERCONNECT PER CODE
- ⊙ CARBON MONOXIDE DETECTOR ONE PER FLOOR

STEPS PER CODE
CONTRACTOR TO PROVIDE RAIL
PER CODE WHERE ELEVATION CHANGE
IS GREATER THAN 30" PER 2020 NYS CODE

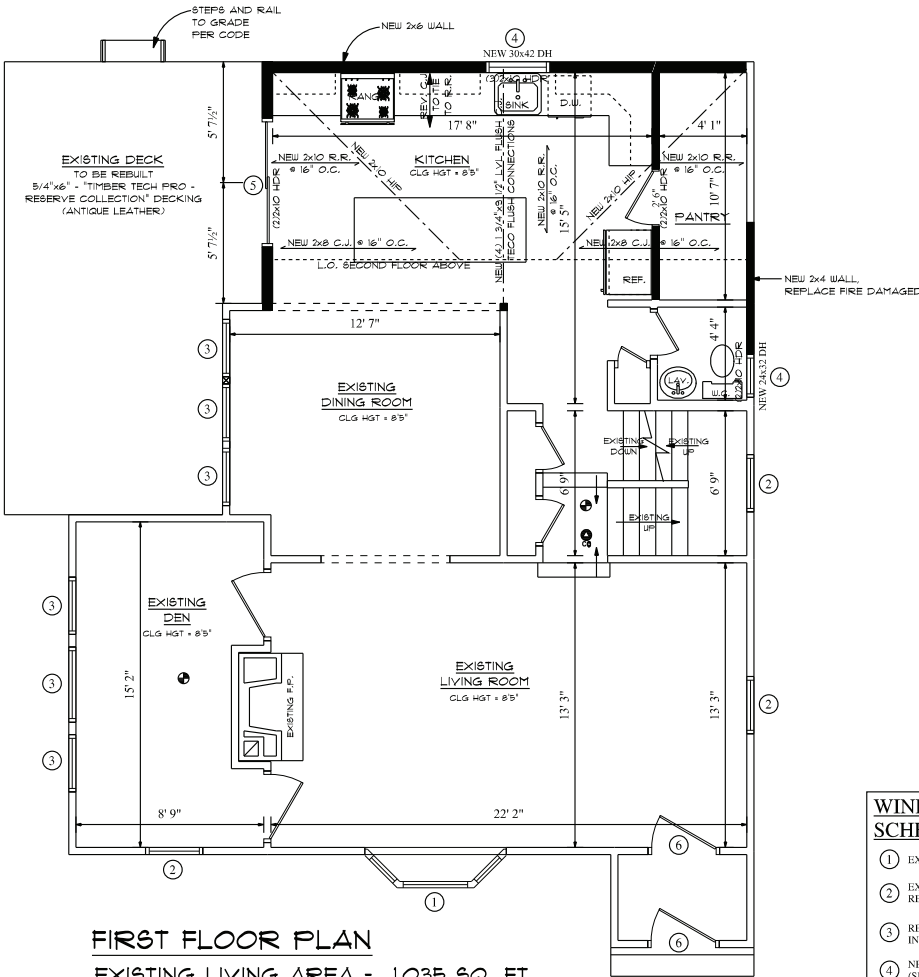

FIRST FLOOR PLAN
EXISTING LIVING AREA = 1,035 SQ. FT.

- ① SMOKE DETECTOR INTERCONNECT PER CODE
- ② CARBON MONOXIDE DETECTOR ONE PER FLOOR

WALL LEGEND

EXISTING WALL TO REMAIN
PROPOSED 2x4 WALL FOLLOW NAILING SCHEDULE
PROPOSED 2x6 WALL FOLLOW NAILING SCHEDULE
EXISTING WALL TO BE REMOVED

WINDOW/DOOR SCHEDULE

①	EXISTING WINDOW TO REMAIN
②	EXISTING WINDOW TO BE REPLACED IN-KIND
③	REPLACE DAMAGED WINDOW IN EXISTING OPENING
④	NEW WINDOW IN NEW OPENING (SIZE AS NOTED)
⑤	NEW 6'0"X6'8" SLIDER
⑥	EXISTING DOOR TO REMAIN
⑦	REPLACE DAMAGED DOOR IN EXISTING OPENING

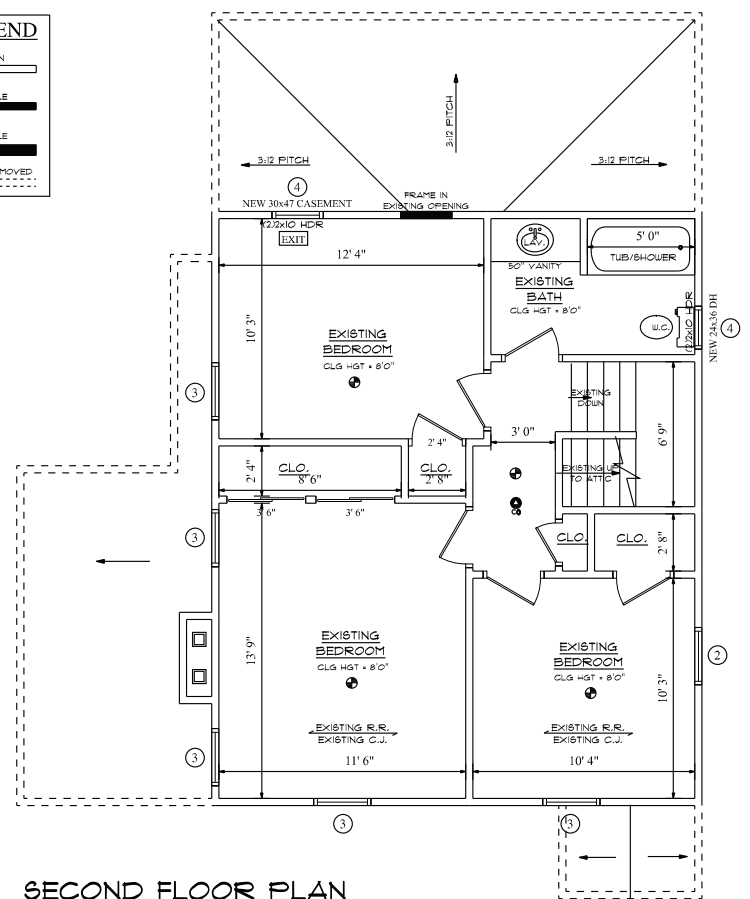

SECOND FLOOR PLAN
EXISTING LIVING AREA = 632 SQ. FT.

- ① SMOKE DETECTOR INTERCONNECT PER CODE
- ② CARBON MONOXIDE DETECTOR ONE PER FLOOR

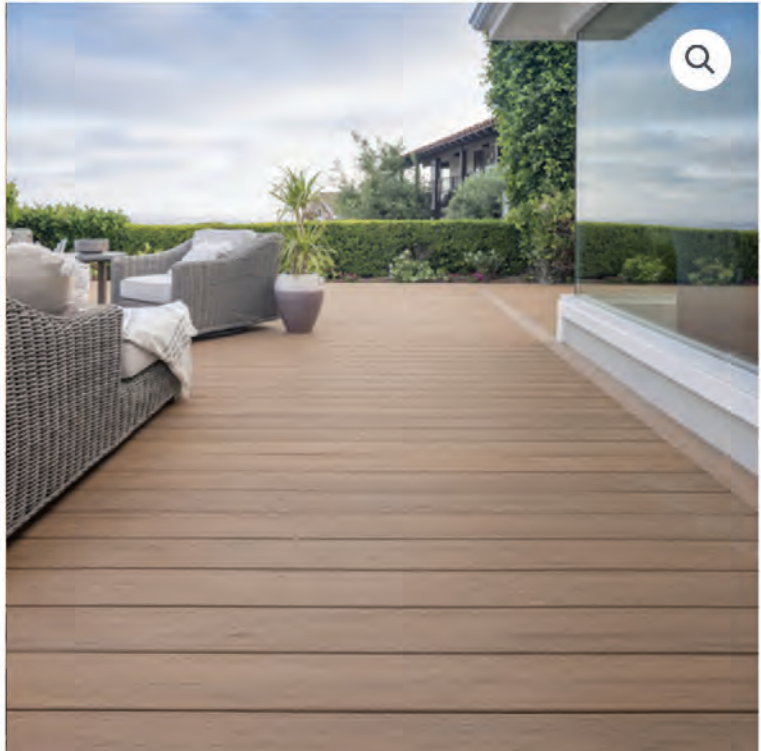

TIMBERTECH COMPOSITE

Reserve Collection

Reclaimed Wood

Bring the charm of reclaimed wood to your space without the rigorous maintenance of wood. Featuring the rustic character and natural beauty of aged wood, our premium polymer capped composite boards deliver real wood aesthetics you'll never have to sand, stain, or seal.

COLOR ANTIQUE LEATHER



SAMPLE SIZE

1' Sample

FREE \$0.00

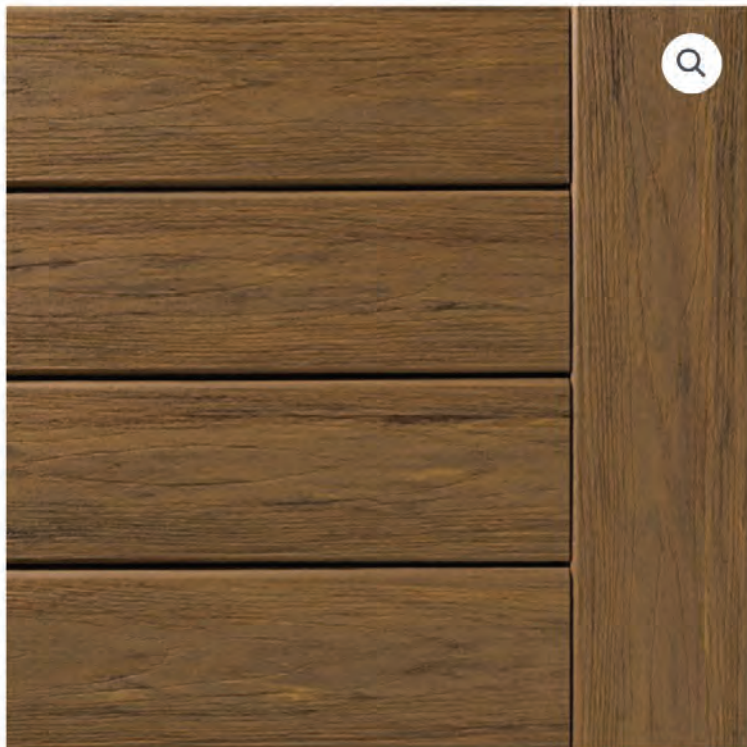
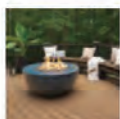

TIMBERTECH COMPOSITE

Reserve Collection

Reclaimed Wood

Bring the charm of reclaimed wood to your space without the rigorous maintenance of wood. Featuring the rustic character and natural beauty of aged wood, our premium polymer capped composite boards deliver real wood aesthetics you'll never have to sand, stain, or seal.

COLOR ANTIQUE LEATHER



SAMPLE SIZE

1' Sample

FREE \$0.00

\$0.00



ADD TO CART



DETAILS

OPTIONS & DIMENSIONS

INSTALLATION & WARRANTY

FAQS

Deck Boards

- Actual dimensions: 5.36" x 0.94"
- Lengths available:
Square-Shoulder 16' and 20'
Grooved 12', 16', and 20'

Riser Boards

- Actual dimensions: 0.58" x 7.25"
- Lengths available: 12'

Fascia Boards

- Actual dimensions: 0.58" x 11.95"
- Lengths available: 12'

For WUI-Compliant boards, specify Fire-Resistant Reserve Collection when purchasing.



TIMBERTECH COMPOSITE

Reserve Collection

Reclaimed Wood

Bring the charm of reclaimed wood to your space without the rigorous maintenance of wood. Featuring the rustic character and natural beauty of aged wood, our premium polymer capped composite boards deliver real wood aesthetics you'll never have to sand, stain, or seal.

COLOR ANTIQUE LEATHER



SAMPLE SIZE

● 1' Sample

FREE \$0.00

\$0.00

-	1	+
---	---	---

ADD TO CART





Residential Reference Guide

The one-stop guide from North America's largest roofing manufacturer

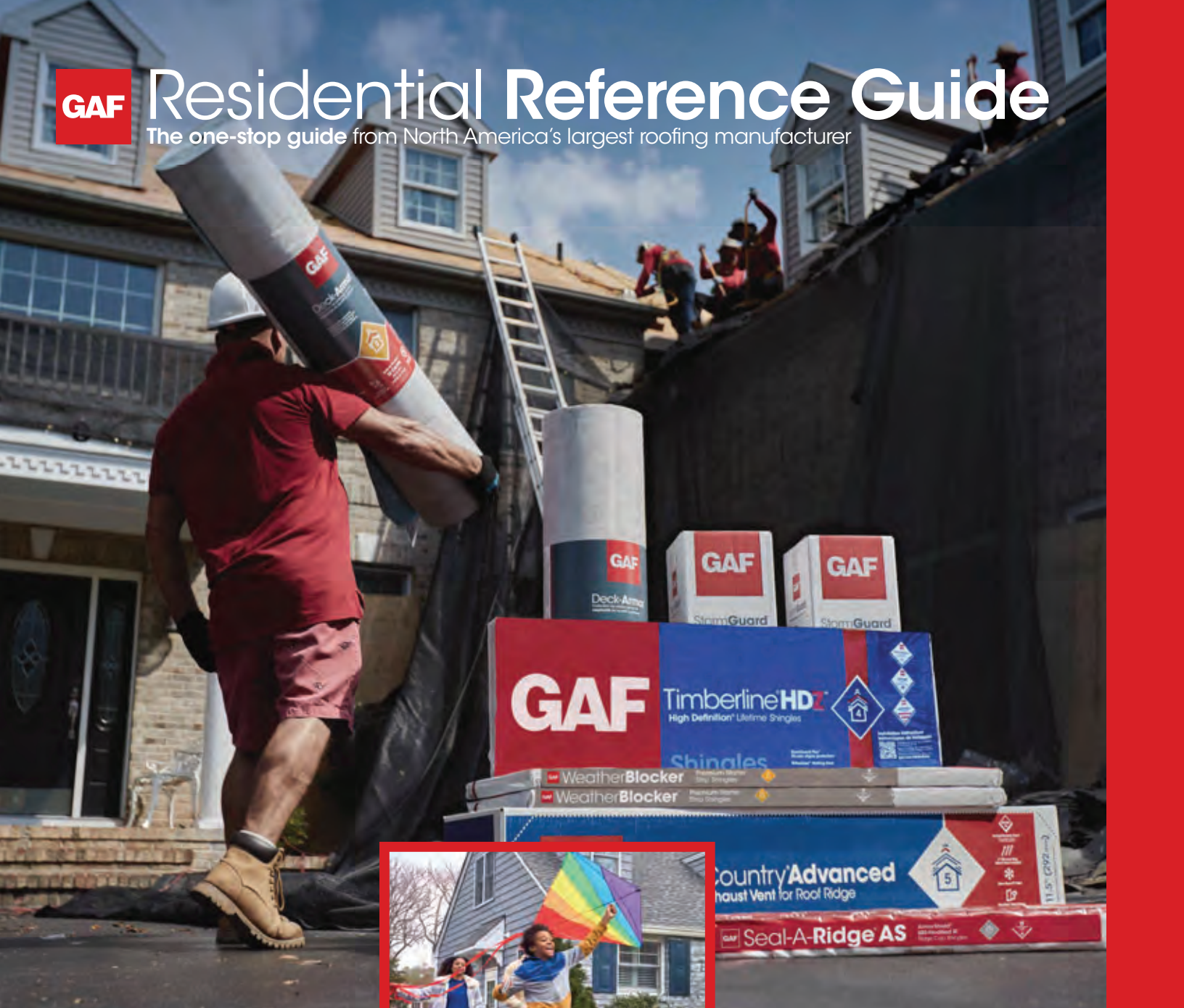

GAF shingles and roof accessories are made to work together. They provide a system that's built to protect homes—so the people who live inside them can enjoy what matters most.











We protect what matters most™

	LRS	Pages
Technology Index		3
GAF Lifetime [†] Roofing System LRS		4–5
GAF Shingles		6–19
Timberline[®] Lifetime[†] Shingles Collection LRS		
Timberline HDZ [®]	●	8
Timberline [®] UHDZ™	●	9
Timberline[®] NS	●	10
Timberline [®] CS	●	11
Designer Lifetime[†] Shingles[®] Collection LRS		
Grand Canyon [®]	●	13
Camelot [®] II	●	14
Grand Sequoia [®]	●	14
Woodland [®]	●	15
Slateline [®]	●	15
SBS Modified IR Shingles Collection LRS		
Timberline [®] AS II	●	16–17
Grand Sequoia [®] AS	●	16–17
3-Tab Shingle Collection (Excluded from LRS)		
Royal Sovereign [®]		18–19
Shingle Specifications Chart		20–21
GAF Roofing Accessories LRS		
Leak Barriers	●	23
Roof Deck Protection	●	24
Starter Strip Shingles	●	25
Cobra [®] Attic Ventilation	●	26
Ridge Cap Shingles	●	27
Other Products		
Master Flow [®] Ventilation Products		28
WeatherSide™ Fiber-Cement Siding		29
ThermaCal [®] Building Envelope Insulation Panels		30
LIBERTY™ Self-Adhering Roofing System		31



Trust the diamonds

Whether it's warranty coverage that gives homeowners peace of mind or technology that makes their roof look and perform its best, there's a GAF diamond badge behind it.

	Install any GAF Lifetime [†] Shingle and get a Lifetime[†] Limited Warranty on your qualifying shingle. Install any GAF Lifetime [†] Shingle and at least 3 qualifying GAF Accessories, and get a Lifetime[†] Limited Warranty on your qualifying GAF products.
	GAF Advanced Protection[®] Shingle Technology uses highly advanced design and manufacturing techniques to produce cutting-edge roofing products.
	Dura Grip[™] Adhesive helps protect your roof investment from winds and wind-driven rain.
 	Comes with a 25-year StainGuard Plus[™] or 30-year StainGuard Plus PRO[™] (as indicated) Algae Protection Limited Warranty¹ against blue-green algae discoloration and GAF Time-Release Algae-Fighting Technology, which releases copper over time for long-lasting algae-fighting power.
	StainGuard[®] Algae Protection² is a 10-year limited warranty against blue-green algae discoloration.
	LayerLock[®] Technology is a proprietary technology which mechanically fuses the common bond between overlapping shingle layers.
	WindProven[™] Limited Wind Warranty³ is a 15-year limited wind warranty with no maximum wind speed limitation — available when you install the LayerLock [®] -labeled Shingles as well as GAF starter strips, roof deck protection, ridge cap shingles, and leak barrier or attic ventilation.
	25-Year Limited Warranty Term⁴ gives homeowners protection they can trust.
	Patent-pending Dual Shadow Line for sunset shadows all day long.

[†] Lifetime refers to the length of warranty coverage provided and means as long as the original individual owner(s) of a single-family detached residence [or eligible second owner(s)] owns the property where the qualifying GAF products are installed. For other owners/structures, Lifetime coverage is not applicable. Lifetime coverage on shingles requires the use of GAF Lifetime Shingles only. See the *GAF Shingle & Accessory Limited Warranty* for complete coverage and restrictions. Visit gaf.com/LRS for qualifying GAF products.

¹ The 25-year StainGuard Plus[™] or the 30-year StainGuard Plus PRO[™] Algae Protection Limited Warranty against blue-green algae discoloration is available only on products sold in packages bearing the appropriate StainGuard Plus[™] or StainGuard Plus Pro[™] logos. See *GAF Shingle & Accessory Limited Warranty* for complete coverage and restrictions, and qualifying products.

² 10-year StainGuard[®] Algae Protection Limited Warranty against blue-green algae discoloration is available only on products sold in packages bearing the StainGuard[®] logo. See *GAF Shingle & Accessory Limited Warranty* for complete coverage and restrictions, and qualifying products.

³ 15-year WindProven[™] limited wind warranty on GAF Shingles with LayerLock[®] Technology requires the use of GAF Starter Strips, Roof Deck Protection, Ridge Cap Shingles, and Leak Barrier or Attic Ventilation. See *GAF Roofing System Limited Warranty* for complete coverage and restrictions. Visit gaf.com/LRS for qualifying GAF products. For installations not eligible for the *GAF Roofing System Limited Warranty*, see the *GAF Shingle & Accessory Limited Warranty*.

⁴ See *GAF Shingle & Accessory Limited Warranty* for complete coverage and restrictions.

Trust the system that's built to protect

A roof is so much more than shingles. It's layers of protection, working together to help keep your home safe from wind, rain, snow, and even sun.

Install any GAF Lifetime[†] Shingle and at least 3 qualifying GAF Accessories and get a Lifetime[†] limited warranty on your qualifying GAF products plus non-prorated coverage for the first 10 years. For even stronger coverage, ask your GAF factory-certified contractor¹ about enhanced GAF warranties.

Visit gaf.com/LRS for a list of qualifying GAF products.



Visit gaf.com/Lifetime



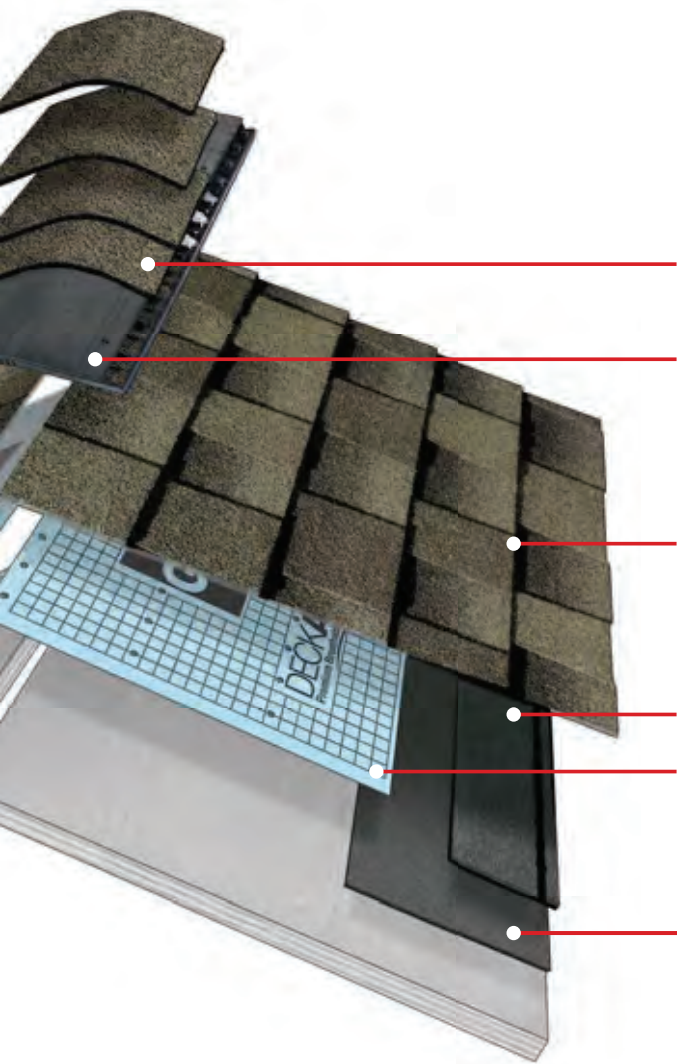

- Ridge Cap Shingles

- Cobra® Attic Ventilation

- Lifetime⁺ Shingles

- Starter Strip Shingles

- Roof Deck Protection

- Leak Barrier

[†]Lifetime refers to the length of warranty coverage provided and means as long as the original individual owner(s) of a single-family detached residence [or eligible second owner(s)] owns the property where the qualifying GAF products are installed. For other owners/structures, Lifetime coverage is not applicable. Lifetime coverage on shingles requires the use of GAF Lifetime Shingles only. See the *GAF Shingle & Accessory Limited Warranty* for complete coverage and restrictions. Visit gaf.com/LRS for qualifying GAF products. Lifetime coverage on shingles and accessories requires the use of any GAF Lifetime Shingle and at least 3 qualifying GAF Accessories. See the *GAF Roofing System Limited Warranty* for complete coverage and restrictions. For installations not eligible for the *GAF Roofing System Limited Warranty*, see the *GAF Shingle & Accessory Limited Warranty*. Visit gaf.com/LRS for qualifying GAF products.

[†]Contractors enrolled in GAF certification programs are not employees or agents of GAF, and GAF does not control or otherwise supervise these independent businesses. Contractors may receive benefits, such as loyalty rewards points and discounts on marketing tools from GAF for participating in the program and offering GAF enhanced warranties, which require the use of a minimum amount of GAF products.

Timberline® Lifetime[†] Shingles Collection

More homeowners in North America rely on Timberline® Shingles than any other brand. They offer just the right combination of beauty, performance, and reliability.

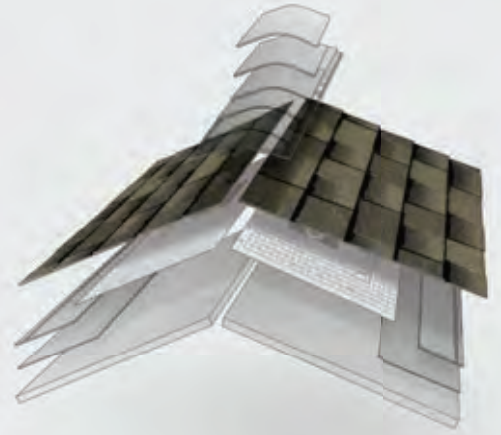

<p>Timberline HDZ® pg 7-8</p>			<p>America's #1-selling shingle—now featuring the industry's widest nail zone</p>
<p>Timberline UHDZ™ pg 7 & 9</p>			<p>For a highly dimensional wood-shake look in an asphalt shingle</p>
<p>Timberline NS pg 10</p>			<p>The beauty of natural wood shakes in an asphalt shingle</p>
<p>Timberline CS pg 11</p>			<p>Our most reflective shingle</p>

For specifications see pages 20-21



For the full collection visit gaf.com/Timberline



[†] 15-year WindProven™ limited wind warranty on GAF Shingles with LayerLock® Technology requires the use of GAF Starter Strips, Roof Deck Protection, Ridge Cap Shingles, and Leak Barrier or Attic Ventilation. See GAF Roofing System Limited Warranty for complete coverage and restrictions. Visit gaf.com/LRS for qualifying GAF products. For installations not eligible for the GAF Roofing System Limited Warranty, see the GAF Shingle & Accessory Limited Warranty.



GAF **Timberline[®] NS**
Natural Shadow[®] Lifetime[†] Shingles



These stylish yet practically priced architectural shingles provide value and performance with a classic shadow effect for a subtle, even-toned look.

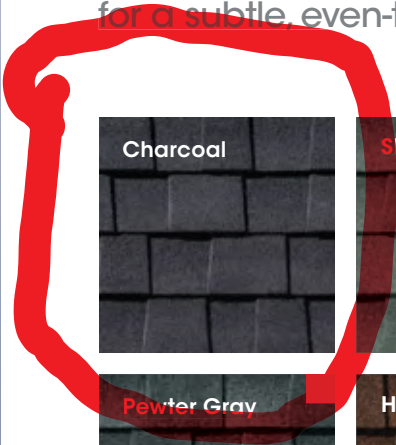

Charcoal



Slate

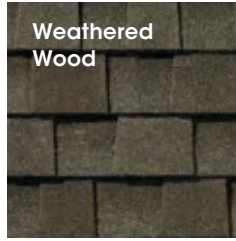

Weathered Wood

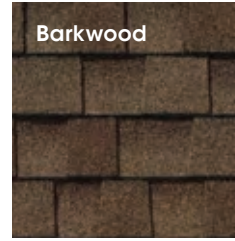

Barkwood

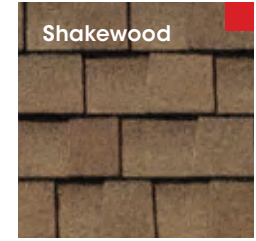

Shakewood



Pewter Gray

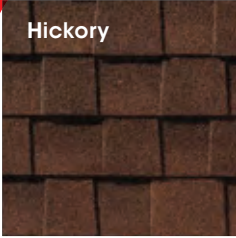

Hickory

Timberline[®] Shingles LRS

For more details visit gaf.com/NS

Shingle Specifications

Shingle	Warranty	Technology	Shingle Construction
Timberline® Lifetime[†] Shingles Collection			
Timberline HDZ®	†, 2, 4		
Timberline® UHDZ™	†, 2, 9		
Timberline® NS	†, 3		
Timberline® CS	†, 2, 4		
Designer Lifetime[†] Shingles Collection			
Grand Canyon®	†, 4		
Grand Sequoia®	†, 4		
Woodland®	†, 4		
Camelot® II	†, 4		
Slateline®	†, 4		
SBS Modified IR Shingles Collection			
Timberline® AS II	†, 2, 4		
Grand Sequoia® AS	†, 4		
3-Tab Shingle			
Royal Sovereign®	1, 3		

[†] Lifetime refers to the length of warranty coverage provided and means as long as the original individual owner(s) of a single-family detached residence [or eligible second owner(s)] owns the property where the qualifying GAF products are installed. For other owners/structures, Lifetime coverage is not applicable. Lifetime coverage on shingles requires the use of GAF Lifetime Shingles only. See the *GAF Shingle & Accessory Limited Warranty* for complete coverage and restrictions. Visit gaf.com/LRS for qualifying GAF products. Lifetime coverage on shingles and accessories requires the use of any GAF Lifetime Shingle and at least 3 qualifying GAF Accessories. See the *GAF Roofing System Limited Warranty* for complete coverage and restrictions. For installations not eligible for the GAF Roofing System Limited Warranty, see the *GAF Shingle & Accessory Limited Warranty*. Visit gaf.com/LRS for qualifying GAF products.

¹ See *GAF Shingle & Accessory Limited Warranty* for complete coverage and restrictions.

² 15-year WindProven™ limited wind warranty on GAF Shingles with LayerLock® Technology requires the use of GAF Starter Strips, Roof Deck Protection, Ridge Cap Shingles, and Leak Barrier or Attic Ventilation. See *GAF Roofing System Limited Warranty* for complete coverage and restrictions. Visit gaf.com/LRS for qualifying GAF products. For installations not eligible for the *GAF Roofing System Limited Warranty*, see the *GAF Shingle & Accessory Limited Warranty*.

³ 10-year StainGuard® Algae Protection Limited Warranty against blue-green algae discoloration is available only on products sold in packages bearing the StainGuard® logo. See *GAF Shingle & Accessory Limited Warranty* for complete coverage and restrictions, and qualifying products.

 certainteed
SAINT-GOBAIN

MainStreet™

Siding



Life happens here.™

SAINT-GOBAIN

Choose exceptional value with versatility.

7 styles. 25 colors. MainStreet's attractive, feature-rich siding is the ideal choice for your home. Designed to stay beautiful with very little effort, MainStreet offers unparalleled versatility to design your home based on your unique taste with durability and the benefits of low-maintenance living.



On cover:

Siding: MainStreet Double 4" Clapboard in flagstone and Cedar Impressions Double 7" Perfection Shingles in sterling gray.

Trim: Vinyl Carpentry® & Restoration Millwork®.



On average, **vinyl siding saves time and money** when compared to maintaining other siding options or painted exteriors.*



\$5
vinyl siding / soap
and water



**\$3,500-
5,000**
other siding / paint

Source: costhelper.com

*For 3000 sq. ft., multi-story home, professionally painted, with repainting every 8-10 years.

Curb appeal is an **important consideration** for home buyers when it comes to home exteriors.

Good curb appeal can

**add
14%**
to the value
of your home

Source: *Journal of Real Estate Finance and Economics*

Enjoy the benefits of consistent quality.



Lifetime Limited Warranty



RigidForm™ Technology



PermaColor™ Protection

Not all vinyl siding is the same. A building industry leader for over 100 years, CertainTeed offers a lifetime limited warranty based on MainStreet's quality features – RigidForm™ technology for reinforced performance, PermaColor™ for lifetime fade protection and STUdfinder™ for precision installation.

Installing vinyl siding is a smart investment, with **one of the highest returns** of any major home remodeling project when it's time to sell.

94.7%

Return on investment
for vinyl siding

Source: *Remodeling* magazine
2023 Cost vs. Value Report

Siding: MainStreet Double 5" Clapboard in pacific blue.
Trim: Vinyl Carpentry & Restoration Millwork.



Rollover Nail Hem

Partial Rollover Nail Hem technology stiffens siding for a straighter-on-the-wall appearance. Designed and tested to withstand windload pressures up to 170 mph.

*Products adhere to ASTM D3679 standards for capable wind speed ratings based on standard wind load design pressure ratings. For most current ratings, please reference www.certainteed.com.

Authentic Textures

Natural cedar (woodgrain) or freshly painted (brushed) finishes.

DuraLock[®]

This locking system snaps tight for a secure fit.



7 Styles. Great features.

Low Maintenance

High quality vinyl does not absorb moisture or rot.

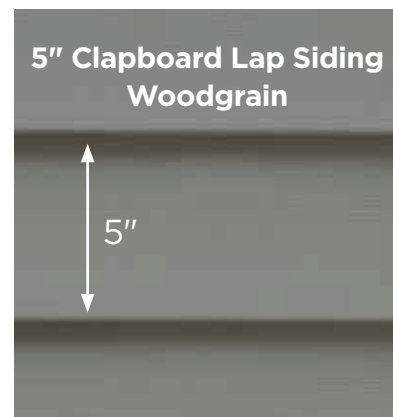
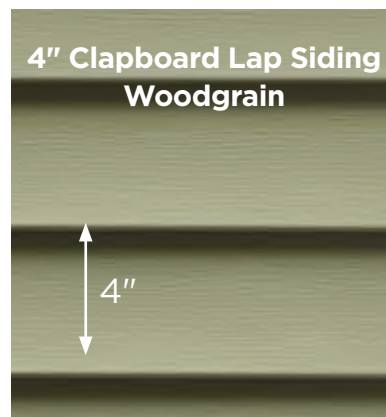
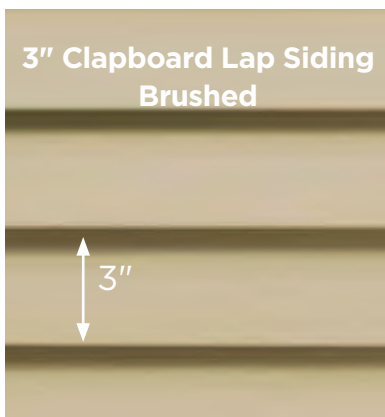



4" DUTCHLAP

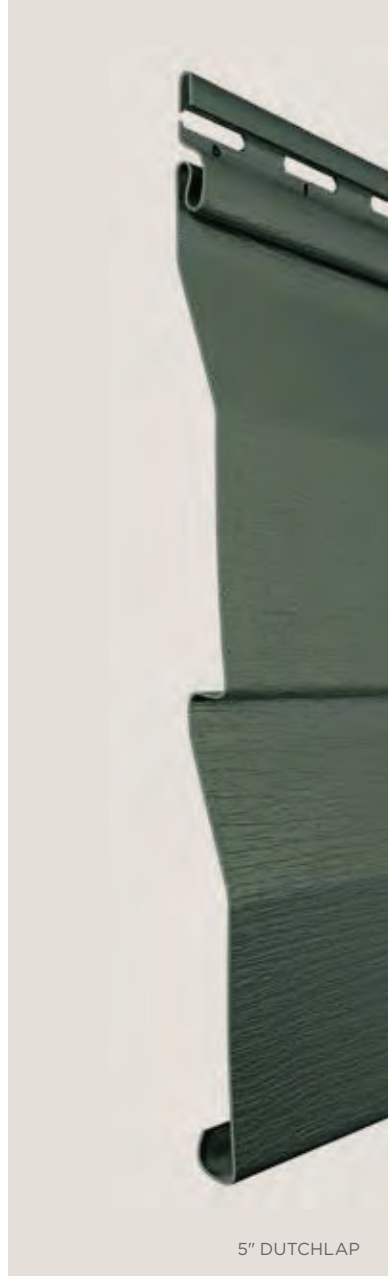

5" DUTCHLAP



8" CLAPBOARD



6-1/2" BEADED

MainStreet consists of traditional styles with European roots: Clapboard, Beaded and Dutchlap. The Clapboard style is the most traditional and found in all parts of the United States. Beaded siding is very popular style for homes in the Southern Coastal regions. The Dutchlap style provides strong shadow lines and is highly popular in the Mid-Atlantic region.

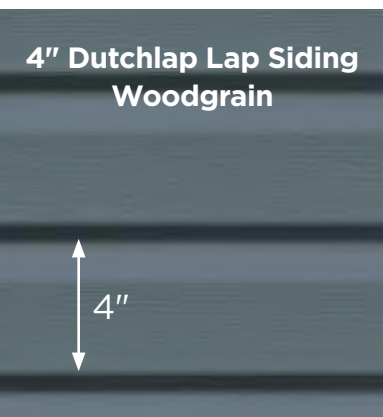

4" Dutchlap Lap Siding
Woodgrain

4"

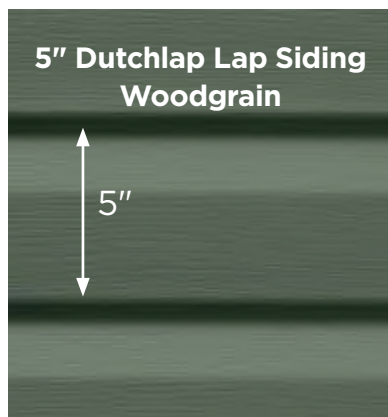

5" Dutchlap Lap Siding
Woodgrain

5"

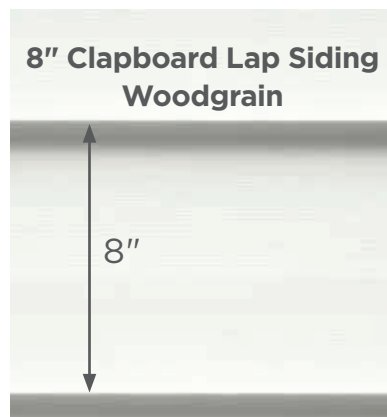

8" Clapboard Lap Siding
Woodgrain

8"

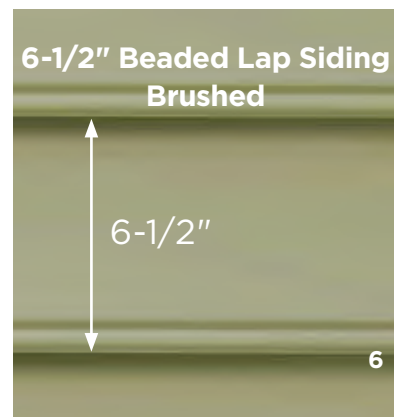

6-1/2" Beaded Lap Siding
Brushed

6-1/2"

MainStreet is better...

Siding: MainStreet Double 5" Clapboard in granite gray.
 Trim: Vinyl Carpentry® & Restoration Millwork®.



...for color availability.

	Autumn Red*	Sable Brown*	Hearthstone*	Spruce*	Forest*	Pacific Blue*	Wedgewood Blue	Flagstone*	Charcoal Gray*	Castle Stone	Granite Gray	Sterling Gray	Oxford Blue	Seagrass	Cypress	Herringbone	Sandstone Beige
3" Clapboard Brushed												•	•				•
4" Clapboard Woodgrain	•	•	•	•	•	•	•	•	•	•	•	•	•	•	•	•	•
5" Clapboard Woodgrain	•	•	•	•	•	•	•	•	•	•	•	•	•	•	•	•	•
4" Dutchlap Woodgrain	•	•	•	•	•	•	•	•	•	•	•	•	•	•	•	•	•
5" Dutchlap Woodgrain	•	•	•	•	•	•	•	•	•	•	•	•	•	•	•	•	•
6-1/2" Beaded Brushed											•	•			•		•
8" Clapboard Woodgrain																	

*Deluxe Colors

...for safety.

STUDfinder™ is an installation system with letters on the MainStreet's panel nail hem to ensure proper nailing to wood studs, to protect you from unwanted dangers such as damaged pipes or wires, or exposed nails.

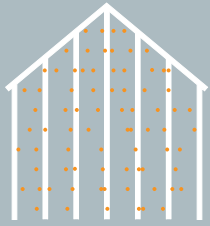

Without STUDfinder

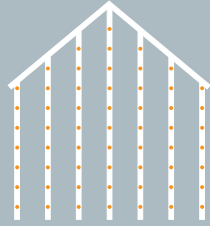

With STUDfinder



...for protection.

When installed with MainStreet siding, CertaWrap™ Weather Resistant Barrier is the added layer of protection against air and moisture damage.

...for peace of mind.



Warranty

MainStreet has a lifetime limited warranty.

#1

Trusted Brand

CertainTeed siding is the brand preferred by building professionals and homeowners, from surveys conducted by national trade magazines. CertainTeed is an industry leader for over 100 years.



Sustainable

CertainTeed vinyl siding offers significantly lower environmental impact than other cladding options.*

*Based on life cycle assessment studies conducted through the National Institute of Standards and Technology (NIST)

•	•	•	•	•	•	•	•
•	•	•	•	•	•	•	•
•	•	•	•	•	•	•	•
•	•	•	•	•	•	•	•
•	•	•	•	•	•	•	•
•	•	•	•	•	•	•	•
•	•	•	•	•	•	•	•
•	•	•	•	•	•	•	•
Desert Tan	Weathered Wood	Natural Clay	Savannah Wicker	Heritage Cream	Autumn Yellow	Snow	Colonial White



Long-Lasting Colors

PermaCOLOR™ System assures color performance, resistance and durability. Utilizing the newest technology and state-of-the-art formulations, CertainTeed backs their vinyl siding with PermaCOLOR Lifetime Fade Protection.



We can help with your decisions.

What is your color and design comfort level?

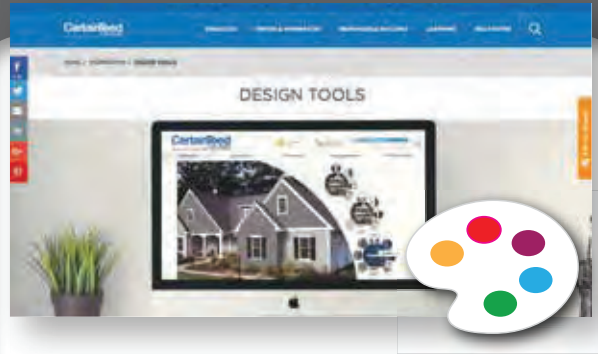

Color and Design Tools
www.certainteed.com/colortools

NOVICE

You are not sure about colors and are not sure where to start.



Online

Mix and match colors and styles on a wide variety of pre-populated home styles to get ideas.

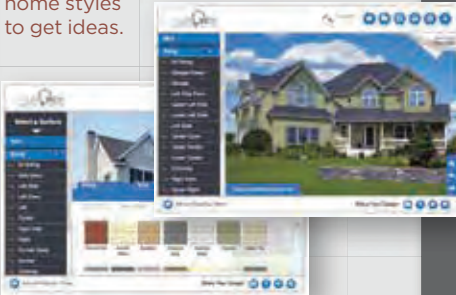

ColorCoach™

Gives you a virtual swatchbook to get started.



INTERMEDIATE

You understand color and enjoy experimenting with color combinations but aren't exactly sure which color direction you want to go.



DIY

Immediately begin designing by uploading a project picture and quickly mix and match products on your own project.



EXPERT

You already know what colors you want to use, but would like to see how the products available in your color theme will look together on your home.



Pro

Have a photo of your home professionally masked in a few days so you can visualize in ColorView tool.



Siding: MainStreet Double 4" Woodgrain Clapboard in cypress.

Trim: Vinyl Carpentry® & Restoration Millwork®.

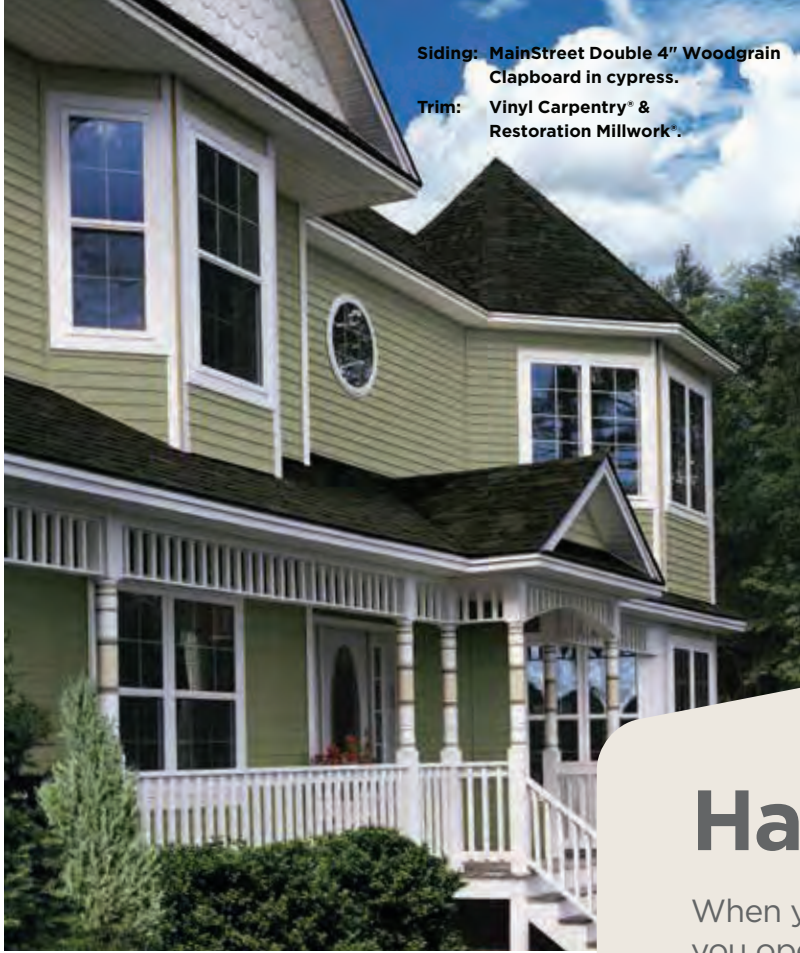

Siding: MainStreet Single 8" Clapboard in colonial white.

Trim: Vinyl Carpentry® & Restoration Millwork®.



Happily ever after.

When you choose MainStreet siding for your home, you open a wide world of color and style options to express your personal design preferences. Add that to the industry-leading quality and low-maintenance performance of MainStreet and you rest assured knowing that your family will enjoy the beautiful sanctuary you have created for years to come.



Siding: MainStreet Double 4" Woodgrain Clapboard in flagstone.

Trim: Vinyl Carpentry® & Restoration Millwork®.

CertainTeed products are designed to work together and complement each other in color and style to give your home a beautiful finished look.

Polymer Shakes and Shingles

Roofing and Ventilation

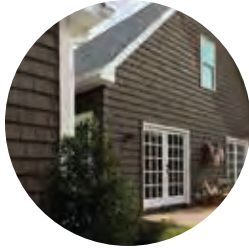

Vinyl Siding

Housewrap



Insulated Siding

Stone

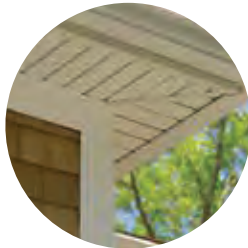
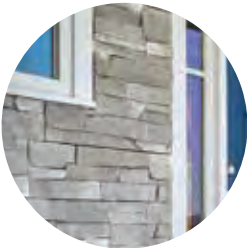

Vinyl & metal soffit

Vinyl Carpentry® Trim

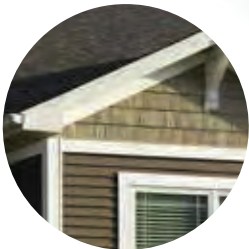

PVC Exterior Trim and Beadboard



Metal Siding





Silver Line

WINDOWS • DOORS™



V3

SERIES

V1

SERIES



V1 Series single-hung windows

The easy choice for reliable, affordable windows.

Whether you're replacing windows, expanding your home or building new from the ground up, Silver Line provides the reliability, low maintenance and affordability you're looking for in a vinyl window or patio door. We manufacture our products with proven, high-tech processes such as fusion welding for added durability and weathertightness. This standard of quality and attention to detail has been part of our heritage for 70 years.



Something for every home.

Not every home requires the same solution. Not every homeowner has the same taste. With a range of solutions, Silver Line® windows and patio doors have just what you need to help make your house your home.



Energy efficient in any climate.

Silver Line products are ENERGY STAR® certified, which results in greater energy efficiency virtually anywhere you live, helping to reduce energy bills and make your home more comfortable year-round.

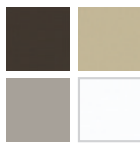

Options that fit your style.

No matter what style of home you'd like to create, our window types, color options and grille pattern choices help personalize your windows and doors.



Windows for new construction.

To help make installation and finishing easier, we offer a variety of frame types. Choose from full-frame windows with a **nailing flange** for installation in most rough openings, a **nailing flange with J-channel** for easy trimming of the siding to the window or a **masonry flange** for installation in homes with masonry block construction. In addition to new construction, all of these window types may be used for replacement projects.

Window replacement made easy.

Silver Line offers insert windows that fit into your existing window frames. Insert windows improve energy efficiency and sash operation, and offer the appearance of new windows while saving time and money. Plus, there's no need to remove your home's interior or exterior trim, so there's less disruption to your home.



Tougher windows for coastal areas.

Impact-resistant glass and structural upgrades are available to meet tough coastal area building codes. See your local building code official for specific requirements.

V3 SERIES



V1 SERIES



A range of choices for a variety of homes.

Whether you prefer traditional styling, a contemporary look, a lot of options or just the basics, there are two series of Silver Line® windows and patio doors to help meet your needs and your budget.



V3 SERIES

FEATURES

- Enhanced styling and performance
- A full portfolio, offering a variety of features, options and sizes
- Available with glass options that are ENERGY STAR® certified for greater energy efficiency
- Low-maintenance vinyl construction inside and out
- Custom sizes available
- Backed by Limited Lifetime Warranty*

V1 SERIES

FEATURES

- Simple design with slim profiles
- Most popular features, options and sizes
- Available with glass options that are ENERGY STAR® certified for greater energy efficiency
- Low-maintenance vinyl construction inside and out
- Custom sizes available
- Backed by Limited Lifetime Warranty*



Window & patio door types.

There are many types of windows that differ not only in appearance, but also in how they function. Depending on your home's style or your needs, you may wish to choose more than one type of window for your home.



V3 Series arch windows

Double-Hung Windows

A double-hung window has two vertically sliding sash in a single frame.

Available in V3 Series & V1 Series. See page 8.

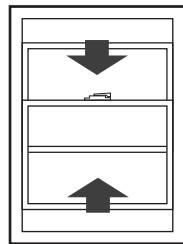

Single-Hung Windows

This window looks like a double-hung, but only the bottom sash moves up and down.

Available in V1 Series. See page 10.

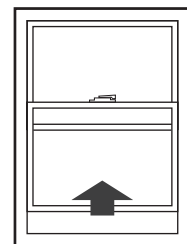

Casement Windows

Casement windows are hinged windows that, with a turn of a crank, open outward to the right or to the left.

Available in V3 Series. See page 12.

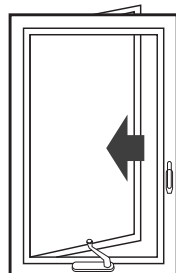

Awning Windows

Awning windows are hinged at the top and open outward.

Available in V3 Series. See page 12.

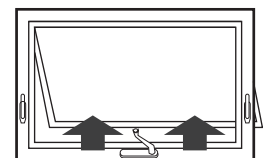

Bay & Bow Windows

Bay and bow windows are window combinations that project outward from a home.

Available in V3 Series. See page 16.

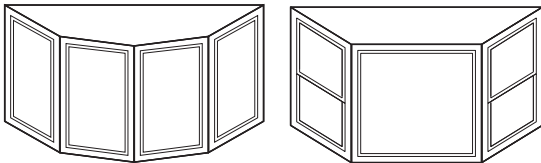

Specialty Windows

Specialty windows are stationary windows characterized by their shapes, including curves and angles.

Available in V3 Series & V1 Series. See page 17.

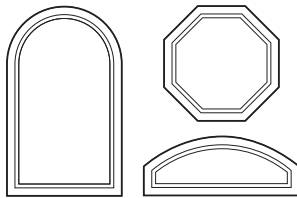

Gliding Windows

Gliding windows feature two sash, with at least one of the sash sliding horizontally past the other.

Available in V3 Series & V1 Series. See page 14.

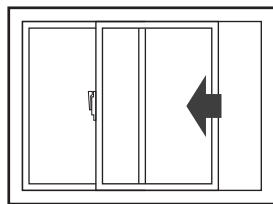

Gliding Patio Doors

Gliding patio doors have one door panel that glides smoothly past another door panel, so they save room both inside and out.

Available in V3 Series & V1 Series. See page 18.

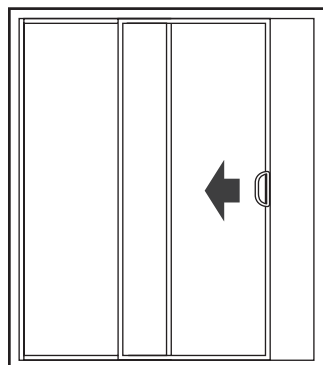

DOUBLE-HUNG WINDOWS



V3 Series double-hung windows

V3 SERIES

Double-Hung Windows

Features and Benefits

- Designed for new construction or easy window replacement
- Colonial brick mould design for classic styling
- Tilt-in top and bottom sash for easy cleaning
- Fusion-welded, heavy-duty vinyl for strength and durability
- Integral J-channel is optional for attractive trimming of exterior siding
- Available with glass options that are ENERGY STAR® certified for greater energy efficiency



V1 SERIES

Double-Hung Windows

Features and Benefits

- Designed for easy window replacement
- Simple beveled design blends with virtually any décor
- Tilt-in top and bottom sash for easy cleaning
- Fusion-welded vinyl for durability
- Available with glass options that are ENERGY STAR® certified for greater energy efficiency



Double-Hung Windows

	V3	V1
--	----	----

	V3	V1
Exterior Colors		
White	■	■
Beige	■	■
Sandstone	■	
Dark Bronze*	■	
Interior Colors		
White	■	■
Beige	■	■
Sandstone	■	
Glass		
Low-E	■	■
Low-E SmartSun™	■	■
Low-E Sun	■	■
Low-E PassiveSun®	■	■
Low-E PassiveSun w/HeatLock®	■	■
Grilles		
Grilles-between-the-glass, Flat Profile	■	■
Grilles-between-the-glass, Contour Profile	■	■
Simulated Divided Light	■	
Insect Screens		
Full	■	■
Half	■	■
Frame Types		
Insert Frame	■	■
Nailing Flange w/J-channel	■	
Nailing Flange	■	
Masonry Flange		
Additional Options		
Custom Sizes	■	■
Coastal Upgrades	□	

□ Limited availability. Check with dealer for details.

*Dark Bronze exterior with White vinyl interior has a 10-year limited warranty. Visit silverlinewindows.com for warranty details.

SINGLE-HUNG WINDOWS



V1 Series single-hung and picture windows

V1 SERIES

Single-Hung Windows

Features and Benefits

- Designed for new construction or easy window replacement
- Simple design blends with virtually any décor
- Tilt-in bottom sash for easy cleaning
- Fusion-welded vinyl for durability
- Integral J-channel is optional for attractive trimming of exterior siding
- Available with glass options that are ENERGY STAR® certified for greater energy efficiency





V1 Series single-hung windows



V1 Series single-hung and transom windows

Single-Hung Windows

V1

Exterior Colors	
White	<input checked="" type="checkbox"/>
Beige	<input checked="" type="checkbox"/>
Sandstone	<input type="checkbox"/>
Dark Bronze*	<input type="checkbox"/>
Interior Colors	
White	<input checked="" type="checkbox"/>
Beige	<input checked="" type="checkbox"/>
Sandstone	<input type="checkbox"/>
Glass	
Low-E	<input checked="" type="checkbox"/>
Low-E SmartSun™	<input checked="" type="checkbox"/>
Low-E Sun	<input checked="" type="checkbox"/>
Low-E PassiveSun®	<input checked="" type="checkbox"/>
Low-E PassiveSun w/HeatLock®	<input checked="" type="checkbox"/>
Grilles	
Grilles-between-the-glass, Flat Profile	<input checked="" type="checkbox"/>
Grilles-between-the-glass, Contour Profile	<input checked="" type="checkbox"/>
Simulated Divided Light	<input type="checkbox"/>
Insect Screens	
Full	<input type="checkbox"/>
Half	<input checked="" type="checkbox"/>
Frame Types	
Insert Frame	<input checked="" type="checkbox"/>
Nailing Flange w/J-channel	<input checked="" type="checkbox"/>
Nailing Flange	<input checked="" type="checkbox"/>
Masonry Flange	<input checked="" type="checkbox"/>
Additional Options	
Custom Sizes	<input checked="" type="checkbox"/>
Coastal Upgrades	<input type="checkbox"/>

Limited availability. Check with dealer for details.

*Dark Bronze exterior with White vinyl interior has a 10-year limited warranty. Visit silverlinewindows.com for warranty details.

CASEMENT & AWNING WINDOWS



V3 SERIES

Casement & Awning Windows

Features and Benefits

- Designed for new construction or easy window replacement
- Wide profiles with a curved detail for an upscale design
- Opens effortlessly for ventilation
- Folding handle eliminates interference with shades or blinds
- Fusion-welded, heavy-duty vinyl for strength and durability
- Dual weatherstripping virtually eliminates drafts for a more comfortable, energy-efficient home
- Integral J-channel is optional for attractive trimming of exterior siding
- Available with glass options that are ENERGY STAR® certified for greater energy efficiency
- On casements, a multi-point locking system operates from a single, low-profile lever for easy use and added security

Casement Window



Awning Window



Casement & Awning Windows

V3

Exterior Colors	
White	■
Beige	■
Sandstone	■
Dark Bronze*	■
Interior Colors	
White	■
Beige	■
Sandstone	■
Glass	
Low-E	■
Low-E SmartSun™	■
Low-E Sun	■
Low-E PassiveSun®	■
Low-E PassiveSun w/HeatLock®	■
Grilles	
Grilles-between-the-glass, Flat Profile	■
Grilles-between-the-glass, Contour Profile	■
Simulated Divided Light	■
Insect Screens	
Full	■
Half	
Frame Types	
Insert Frame	■
Nailing Flange w/J-channel	■
Nailing Flange	■
Masonry Flange	
Additional Options	
Custom Sizes	■
Coastal Upgrades	■

*Dark Bronze exterior with White vinyl interior has a 10-year limited warranty. Visit silverlinewindows.com for warranty details.

GLIDING WINDOWS



V3 SERIES

Gliding Windows

Features and Benefits

- Designed for easy window replacement
- Colonial brick mould design for classic styling
- Durable rollers for smooth operation
- Fusion-welded, heavy-duty vinyl for strength and durability
- Available with glass options that are ENERGY STAR® certified for greater energy efficiency



V1 SERIES

Gliding Windows

Features and Benefits

- Designed for new construction or easy window replacement
- Simple design blends with virtually any décor
- Durable rollers for smooth operation
- Fusion-welded vinyl for durability
- Integral J-channel is optional for attractive trimming of exterior siding
- Available with glass options that are ENERGY STAR® certified for greater energy efficiency



V1 Series gliding windows

Gliding Windows	V3	V1
Exterior Colors		
White	■	■
Beige	■	■
Sandstone	■	□
Dark Bronze*	■	□
Interior Colors		
White	■	■
Beige	■	■
Sandstone	■	□
Glass		
Low-E	■	■
Low-E SmartSun™	■	■
Low-E Sun	■	■
Low-E PassiveSun®	■	■
Low-E PassiveSun w/HeatLock®	■	■
Grilles		
Grilles-between-the-glass, Flat Profile	■	■
Grilles-between-the-glass, Contour Profile	■	■
Simulated Divided Light	■	
Insect Screens		
Full	■	
Half	■	■
Frame Types		
Insert Frame	■	■
Nailing Flange w/J-channel		■
Nailing Flange		■
Masonry Flange		
Additional Options		
Custom Sizes	■	■
Coastal Upgrades	□	

□ Limited availability. Check with dealer for details.

*Dark Bronze exterior with White vinyl interior has a 10-year limited warranty. Visit silverlinewindows.com for warranty details.

BAY, BOW & SPECIALTY WINDOWS



V3 SERIES

Bay & Bow Windows

Silver Line® bay and bow windows offer a large number of options, including exterior colors, interior wood species and finishes, and an insulated seatboard that helps keep your home more energy efficient.

Features and Benefits

- Bay windows are available with casement or double-hung windows in 30° and 45° projections for a classic look
- Bow windows are available with casement windows in 10°, 15°, 22°, 30° or 45° projections and offered with 3, 4 or 5 windows
- Solid wood frame and mullions for excellent strength and durability
- Vinyl exterior for low maintenance
- Adjustable steel cable hanging support system allows for easy window leveling during installation
- Custom sizing available



V3 SERIES **V1** SERIES

Specialty Windows

Silver Line® specialty windows include a variety of options featuring elegant arches, dramatic angles and graceful curves. They may be used alone or in combination with other windows.



V1 Series circle window

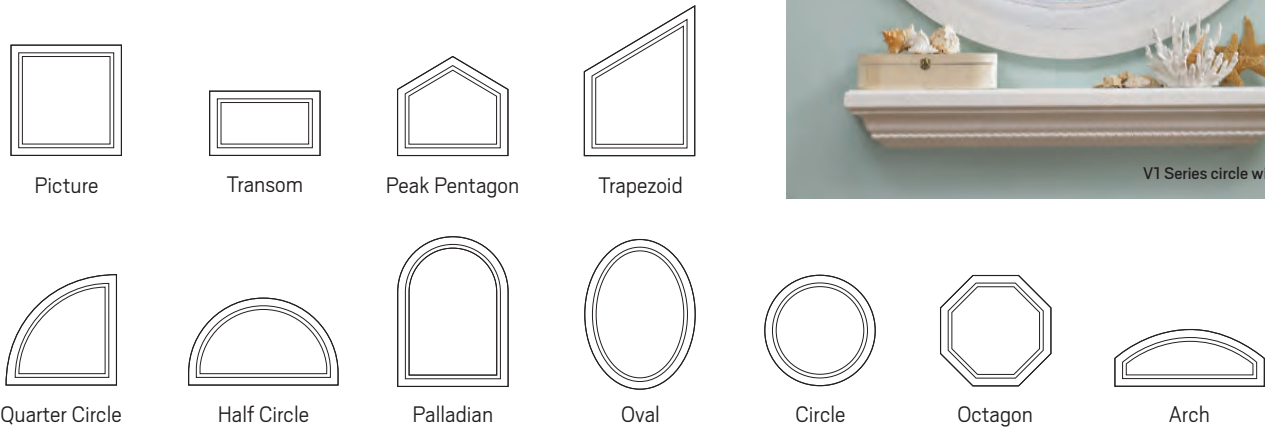

Window Combinations

Silver Line has an expansive selection of window combinations that can add a touch of style or create a stunning focal point for your home.

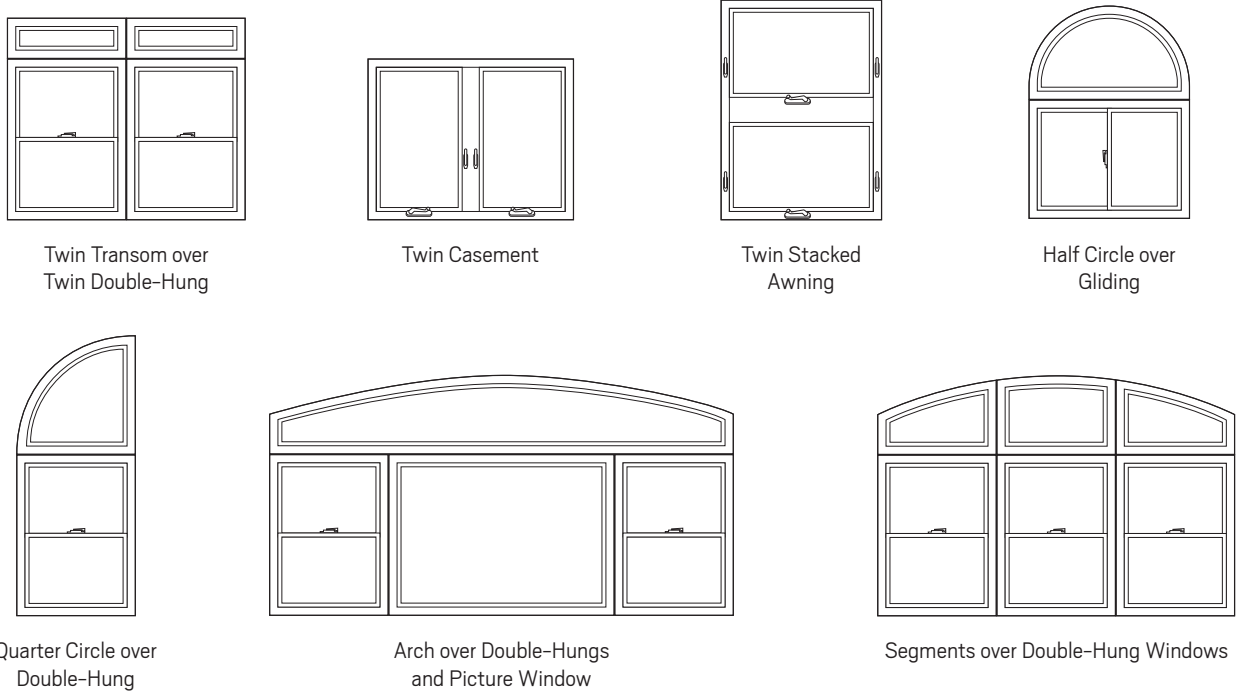

GLIDING PATIO DOORS



V3 SERIES

Gliding Patio Doors

Features and Benefits

- Thick, wide profiles for a traditional appearance
- Fully assembled for fast, easy installation
- Multi-point locking system operates from a single lever for easy, secure locking
- Durable, self-leveling rollers for smooth, effortless operation
- Steel-reinforced panels for added strength
- Fusion-welded, heavy-duty vinyl for strength and durability
- Integral J-channel for attractive trimming of exterior siding
- Exterior keyed lock for your convenience
- Optional Performance Grade rating upgrade is available on many sizes for additional strength and durability
- Optional built-in blinds protect the blinds from damage and never need cleaning
- Available with glass options that are ENERGY STAR® certified for greater energy efficiency



V1 SERIES

Gliding Patio Doors

Features and Benefits

- Simple design blends with virtually any décor
- Available fully assembled for quick installation or as a kit for easy handling
- Fusion-welded vinyl for durability
- Optional built-in blinds protect the blinds from damage and never need cleaning
- Available with glass options that are ENERGY STAR® certified for greater energy efficiency



V1 Series gliding patio door with built-in blinds

Gliding Patio Doors

	V3	V1
Exterior Colors		
White	■	■
Beige	■	■
Sandstone	■	
Dark Bronze*	■	■
Interior Colors		
White	■	■
Beige	■	■
Sandstone	■	
Glass		
Low-E	■	■
Low-E SmartSun™	■	■
Low-E Sun	■	■
Low-E PassiveSun®	■	■
Low-E PassiveSun w/HeatLock®	■	■
Grilles		
Grilles-between-the-glass, Flat Profile	■	■
Grilles-between-the-glass, Contour Profile	■	■
Simulated Divided Light	■	
Insect Screens		
Full		
Half	■	■
Frame Types		
Nailing Flange w/J-channel	■	
Nailing Flange		■
Additional Options		
Custom Sizes	■	
Coastal Upgrades	■	□
Built-in Blinds	■	■

□ Limited availability. Check with dealer for details.

*Dark Bronze exterior with White vinyl interior has a 10-year limited warranty. Visit silverlinewindows.com for warranty details.

OPTIONS

Your home should reflect your style. Silver Line® V3 Series and V1 Series windows and patio doors give you the options you need to do exactly that. Choose from interior and exterior colors, hardware, glass and grille options. They're a beautiful way to personalize your windows, patio doors and your entire home.



V1 Series gliding patio door with Dark Bronze exterior and Satin Nickel handle

Colors

All colors are available in the V3 Series and V1 Series, although some exceptions may apply to individual products. White, Beige and Sandstone windows and doors have the same color on both the interior and exterior and are consistent throughout the frame and sash, making scratches virtually invisible. The Dark Bronze painted color option is available for exteriors only, and has a White interior.



Hardware

V3 Double-Hung & Gliding Windows Decorative Lock

Select V3 Series double-hung and gliding replacement windows have color-coordinated decorative locks. These locks help bring the window sash close together for a snug and secure hold.



V1 Double-Hung, Single-Hung & Gliding Windows Standard Lock

V1 Series double-hung, single-hung and gliding windows have color-coordinated locks. These locks help bring the window sash close together for a snug and secure hold.



V3 Patio Door Handle

A color-coordinated handle set with a key is included. Or choose an optional Satin Nickel finish.



V3 Casement & Awning Windows Folding Handle and Lock

V3 Series casement and awning windows come standard with a color-coordinated folding handle that eliminates interference with shades and blinds. The coordinating lock has a slim profile and is designed for easy operation.



V1 Patio Door Handle

A color-coordinated handle set is included. An optional Satin Nickel handle set with a key is available.



Glass

Silver Line® windows and patio doors are available with a variety of energy-efficient, insulated glass options. This not only helps you to achieve the comfort and energy savings you're looking for, but also makes it possible to get windows and patio doors that are ENERGY STAR® v. 6.0 certified — no matter where you live in the country.



Low-E Glass

Most people can enjoy optimal energy performance and comfort with Low-E glass. Low-E glass reflects heat in the summer and helps keep heat inside in the winter, making this a good choice in climates where both heating and cooling costs are a concern.

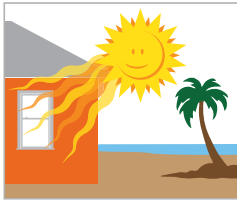

SmartSun™ Glass

SmartSun™ glass gives you the benefits of Low-E glass, plus it helps shield your home from the sun's heat and filters out 95% of harmful UV rays while letting sunlight shine through.

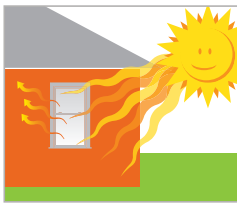

Sun Glass

Sun glass offers outstanding thermal performance with a subtle tint that blocks out even more heat from the sun.

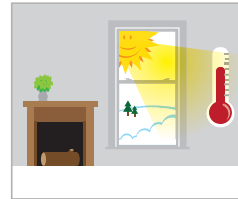

PassiveSun® Glass

If you live in a cold climate, PassiveSun® glass allows the sun to heat your home.



HeatLock® Technology

HeatLock® coating can be added to most of our glass options and reflects heat that likes to escape your home.

Additional glass options including tempered, obscure, tinted and laminated are also available. Contact your Silver Line dealer for details.

Energy Performance Details

	U-FACTOR	SOLAR HEAT GAIN COEFFICIENT	VISIBLE LIGHT TRANSMITTANCE	UV PROTECTION
GLASS	How well a product prevents heat from escaping.	How well a product blocks heat caused by sunlight.	How much visible light comes through a product.	How well a product blocks ultraviolet rays.
Low-E	● ● ● ○	● ● ● ○	● ● ● ●	● ● ● ○
Low-E SmartSun	● ● ● ○	● ● ● ○	● ● ● ○	● ● ● ●
Low-E Sun	● ● ● ○	● ● ● ●	● ● ● ○	● ● ● ●
Low-E PassiveSun	● ● ● ○	● ● ○ ○	● ● ● ●	● ● ● ●
Low-E PassiveSun with HeatLock Technology	● ● ● ○	● ● ○ ○	● ● ● ●	● ● ● ●
Clear Dual Pane (For comparison only)	● ○ ○ ○	○ ○ ○ ○	● ● ● ●	○ ○ ○ ○

Center of glass performance only. Visit silverlinewindows.com for ENERGY STAR® map and NFRC total unit performance data. Not all options are available on all products and in all areas. Silver Line does not warrant that inert gas blend infills (such as Argon gas), sealed in the insulated glass unit at the point of manufacture, will not dissipate over time.

Grilles

Grilles-Between-the-Glass

Grilles-between-the-glass are available on both V3 Series and V1 Series products, giving you the appearance of divided light while making window cleaning easier.

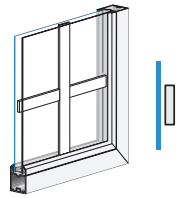

Flat Profile

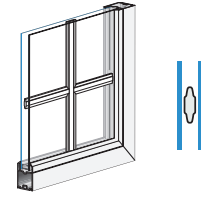

Contour Profile

Simulated Divided Light

Many of our V3 Series windows and patio doors offer Simulated Divided Light (SDL) grilles, which are permanently attached to both sides of the glass to provide the traditional look of individual glass panes. We also offer a simulated check rail on various windows to provide the look of a double-hung window.

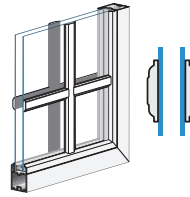

Traditional Simulated Divided Light Grille

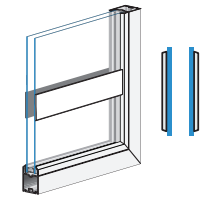

Simulated Check Rail

Grille Patterns

V3 Series and V1 Series windows and patio doors are available with a variety of grille patterns, such as those shown here. Additional patterns are available.

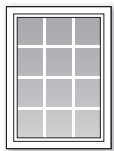

Colonial

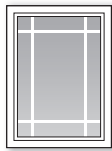

Prairie

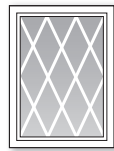

Diamond

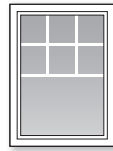

Colonial Upper Sash

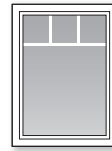

Valance

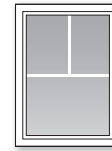

Estate

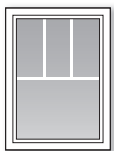

3x1

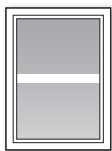

Simulated Check Rail



Custom

Specialty Grille Patterns

Grille patterns are available for specialty windows. Choose from those shown here, or see your dealer for additional options.

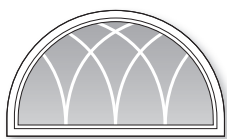

Cathedral



Starburst



Perimeter Prairie

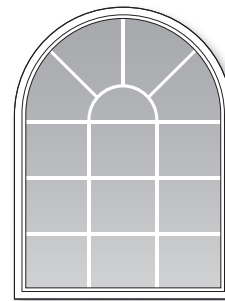

Sunburst

Respect for the environment is nothing new at Silver Line.

At Silver Line, we're committed to conserving natural resources wherever we can, from designing and testing new products that will deliver greater energy savings for our customers to more energy-efficient delivery methods. We understand the importance of creating healthier and more energy-efficient homes.



ENERGY STAR® is a joint program of the U.S. Environmental Protection Agency (EPA) and the U.S. Department of Energy (DOE) that helps consumers save money and protect the environment through energy-efficient products and practices. Silver Line is proud to be an ENERGY STAR partner with our continuing commitment to providing energy-efficient products.



Silver Line® vinyl windows and patio doors have been Home Innovation NGBS Green Certified for both Energy Efficiency and Resource Efficiency. Silver Line achieved these approvals by providing independent third-party results that our vinyl windows and doors perform to the green practice criteria in the National Green Building Standard. As a result, these products are eligible for points toward National Green Building Certification.



Silver Line products are certified under the National Fenestration Rating Council's voluntary third-party certification program designed to ensure accurate energy performance ratings and labeling.



Silver Line proudly participates in the WDMA Hallmark Certification program, which includes product testing and quality control process audits to verify that our windows and doors are produced in conformance with the industry standards for air and water resistance, and structural performance.

silverlinewindows.com



"ENERGY STAR" is a registered trademark of the U.S. Environmental Protection Agency. All trademarks where denoted are marks of their respective owners. ©2018 Ply Gem. All rights reserved.

Case No.	Approximate Time	Address #	Street	Description	Owner	Design Professional
5	8:30 p.m.	183	Aspen Street	2nd Floor Addition	Michael Kurz	Bobby K Architects



183 Aspen Street (Aerial View)

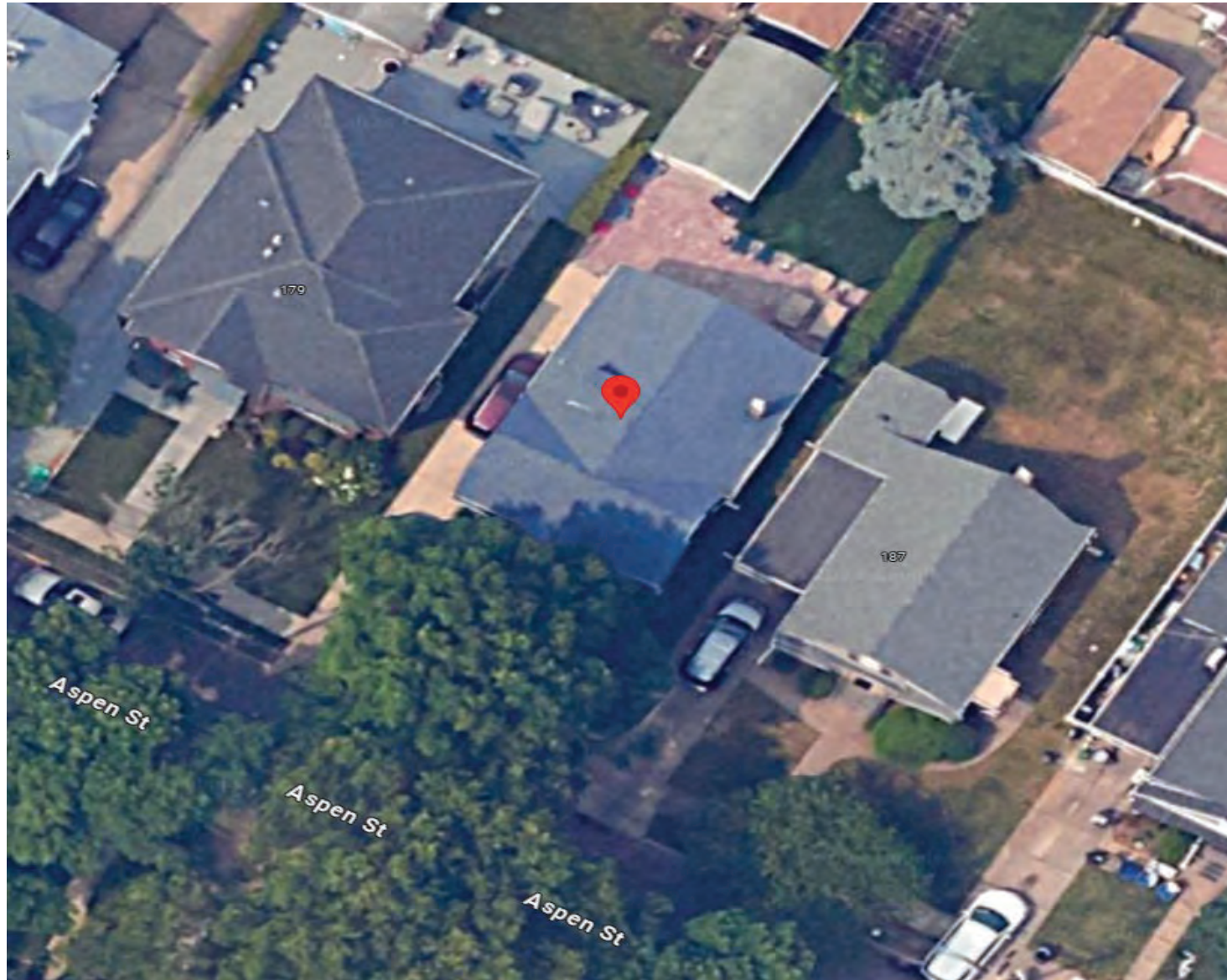

BIRCH STREET

360.00'

100.00'

40.00'

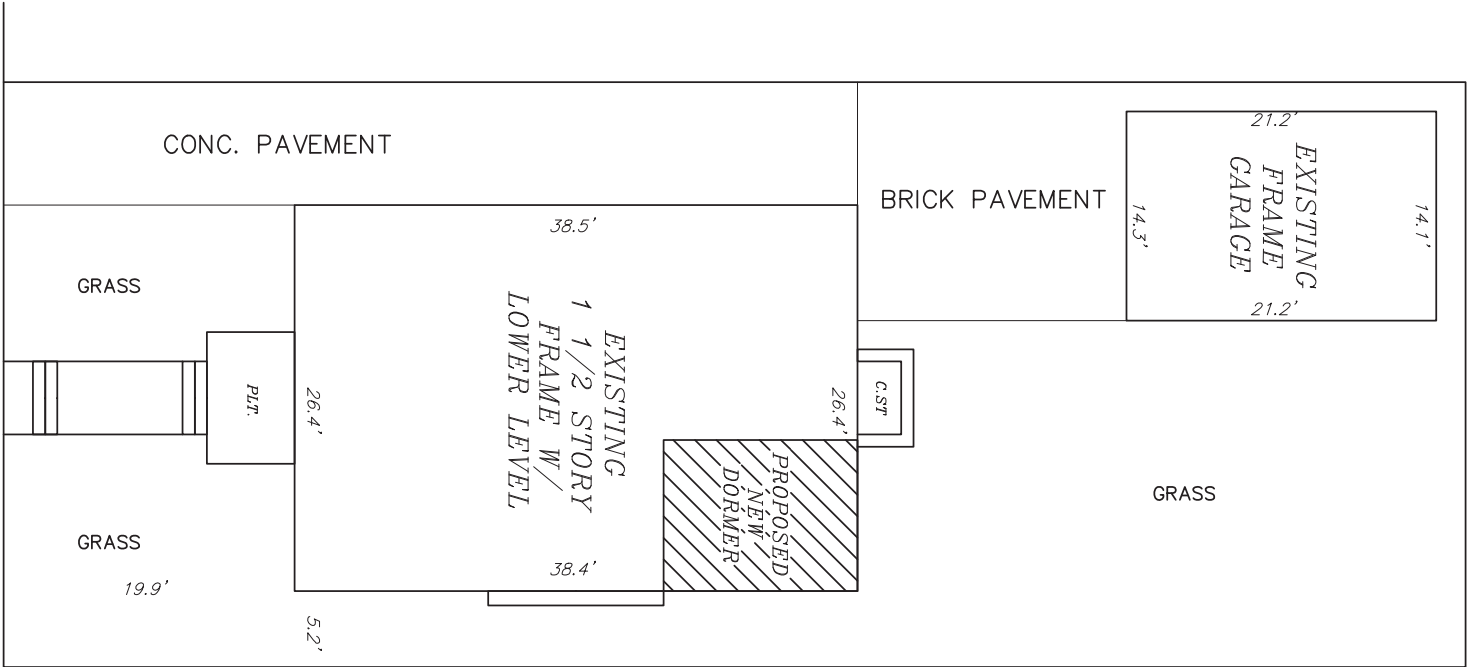

ASPEN STREET

40.00'

100.00'

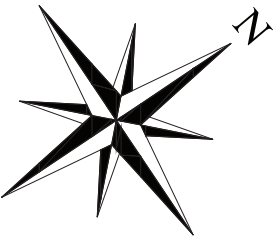

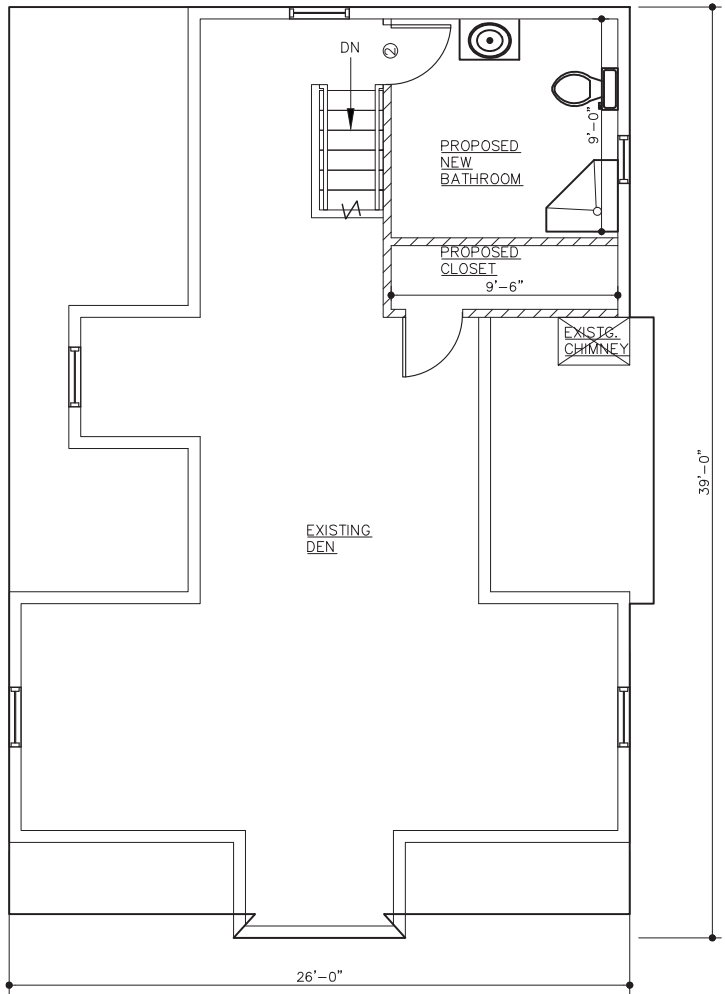

1 PROPOSED SECOND FLOOR PLAN
 SCALE: 1/4" = 1'-0"

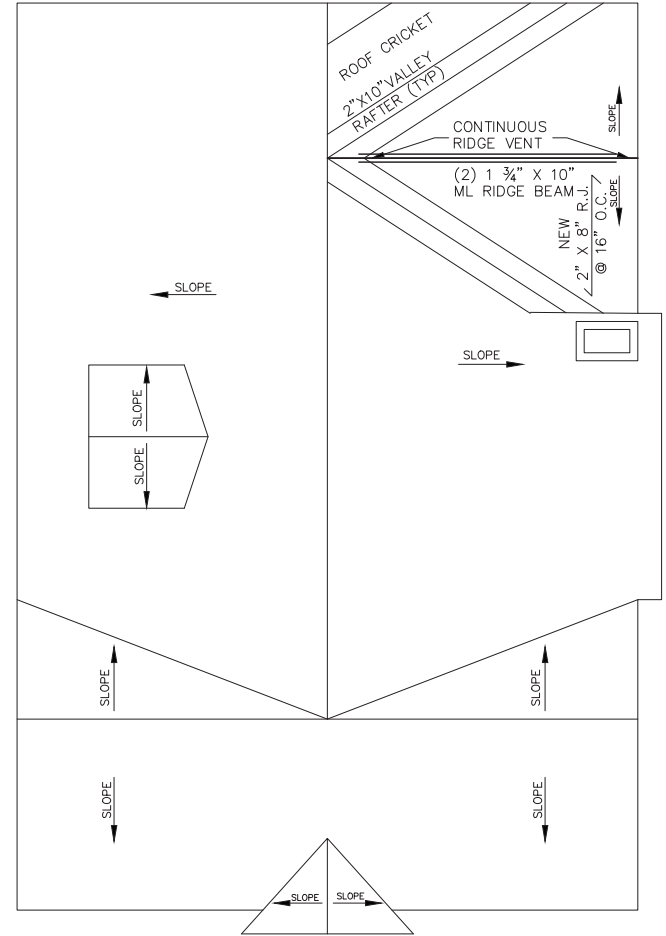

2 PROPOSED ROOF PLAN
 SCALE: 1/4" = 1'-0"



① FRONT ELEVATION
SCALE: 1/4" = 1'-0"



② PROPOSED RIGHT ELEVATION
SCALE: 1/4" = 1'-0"

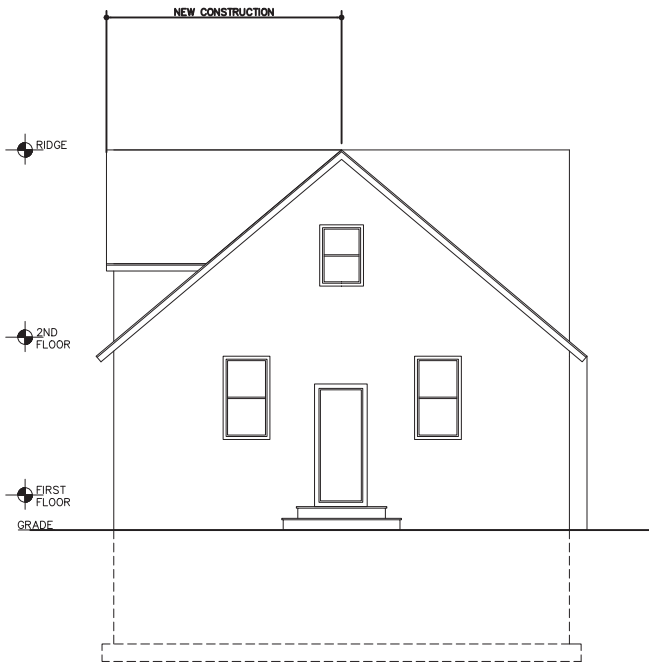

3 REAR ELEVATION
SCALE: 1/4" = 1'-0"

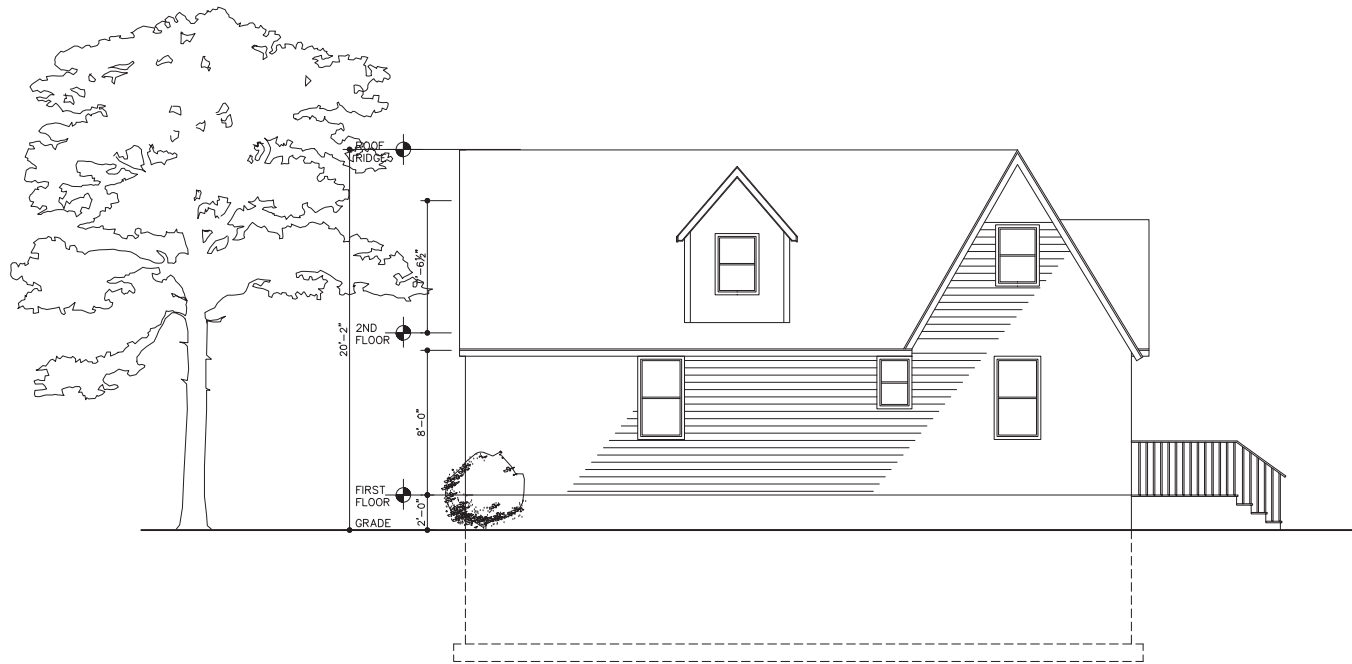

4 LEFT ELEVATION
SCALE: 1/4" = 1'-0"

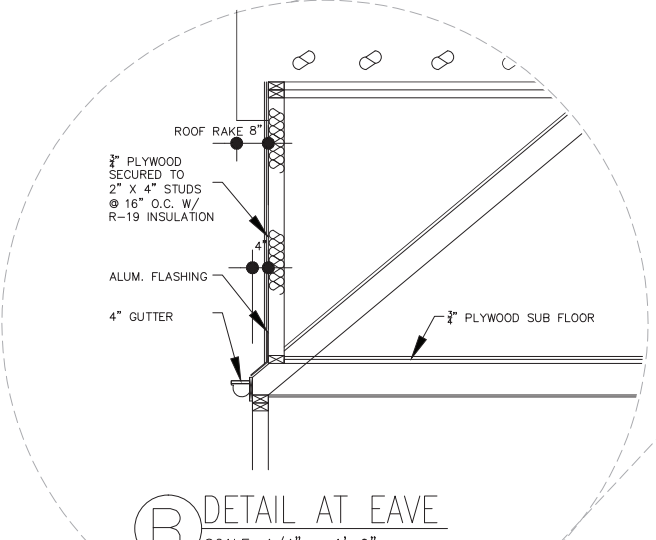
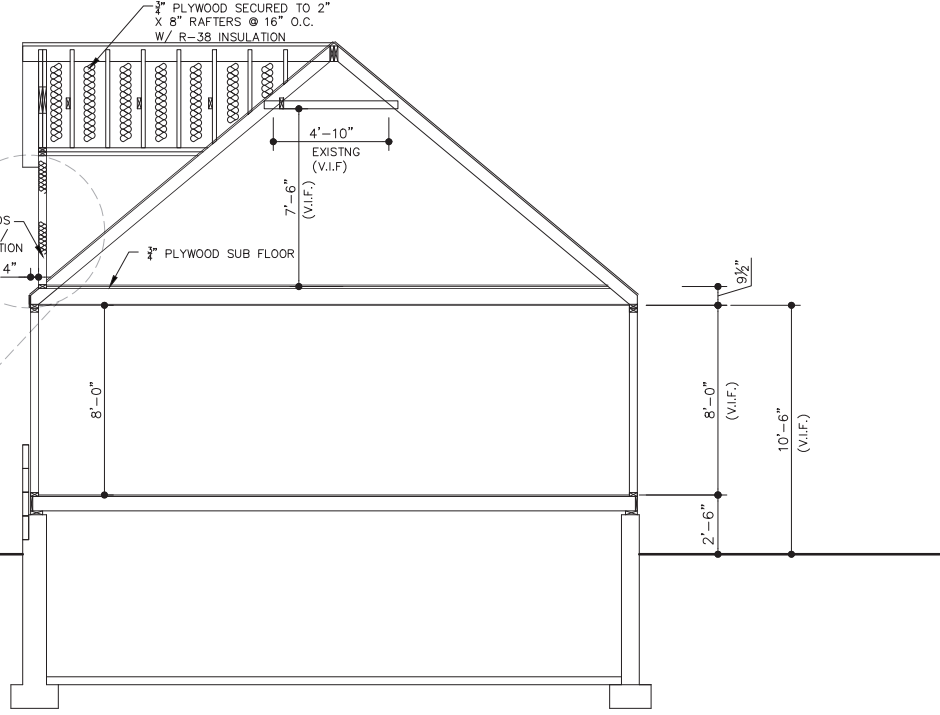
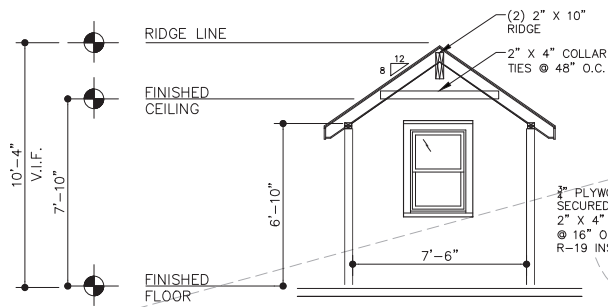

(R) DETAIL AT EAVE

(A) SECTION
SCALE: 1/4" = 1'-0"

METAL CAP. FLASHING

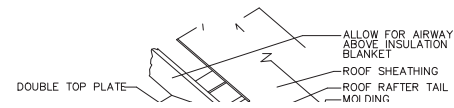

Case No.	Approximate Time	Address #	Street	Description	Owner	Design Professional
6	8:40 p.m.	266	Whitier	Resubmittal Railing	Rajinder Kaur	M. Azeem PE





266

